

LE CERAMICHE



Aldo Bernardi

PASSIONE DI FAMIGLIA

FAMILY PASSION



Aldo Bernardi

Trent'anni di passione e di ricerca hanno portato Aldo Bernardi a creare un proprio stile particolare e "rassicurante", libero da mode e conformismi che ben si riconosce nell'ambito del mercato dell'illuminazione e degli accessori coniugando tradizione e innovazione tecnologica. L'azienda si contraddistingue per una produzione nella quale il carattere artigianale del prodotto, interamente rifinito e decorato a mano, rispecchia un'attività produttiva tipica della zona dei colli asolani.

Thirty years of passion and research have led Aldo Bernardi to create its own style, particular and "reassuring", that is easily recognised in the sphere of the lighting market and its accessories, combining tradition and innovation. The firm distinguishes itself for a production where the characteristic craftsmanship of the product, entirely hand-finished and hand-decorated, reflects a manufacturing process typical of the area, the Asolo hills.

ARTIGIANALITÀ ITALIANA

ITALIAN CRAFTSMANSHIP

La ceramica è un'arte affascinante e ricca di storia la cui lavorazione si è evoluta nel tempo passando da una lavorazione manuale all'utilizzo di tecnologie avanzate che velocizzano la produzione. Aldo Bernardi, nelle sue collezioni, ripropone quest'arte antica, cercando di rimanere quanto più possibile fedele ad una lavorazione manuale, nella quale l'intervento dell'uomo è ancora indispensabile. Il risultato è un prodotto elegante, sobrio, leggero che solo un processo di questo tipo rende possibile.

Ceramics is a fascinating art and rich in history; its working has evolved through time passing from hand working to the use of production accelerating advanced technologies.

Aldo Bernardi, in his collections re-proposes this antique art, trying to be as faithful as possible to the manual working, where the human hand is still indispensable. The result is an elegant product, sober and light, that only a process of this type can make possible.



Concrete

Materiale che Aldo Bernardi presenta in queste proposte di illuminazione. Trattasi di cemento fibrato alleggerito. Partendo dall'esperienza della lavorazione della ceramica, ossia dal "colaggio" della "barbottina" negli stampi di gesso, viene qui utilizzata una base in cemento alleggerito e colabile, molto versatile nell'impiego.

Material used by Aldo Bernardi in these lighting appliances. It's a lightweight fiber concrete. Starting from the ceramic experience, where a mixture of water and clay is poured into a plaster mould, it's used here light pourable cement base, very versatile in use.





L'azione sinergica dei materiali utilizzati per realizzare l'impasto colabile, pur essendo di natura cementizia, permette di ottenere un manufatto omogeneo, levigato, solido ma leggero. La colorazione dell'oggetto viene effettuata manualmente mediante l'utilizzo di prodotti contenenti sali metallici che, penetrando nel calcestruzzo, creano effetti di colore unici per ogni articolo, molto simili alle sfumature della pietra naturale o dell'invecchiato di una patina consunta dal tempo.

The synergistic action of the materials used to achieve the mixture, while being of cement nature, allows to obtain a homogeneous product, sanded, solid but light. The coloring of the object is carried out manually by the use of products containing metal salts which, penetrating into concrete, create unique color effects for each item, very similar to the nuances of the natural stone or of a patina aged by time.

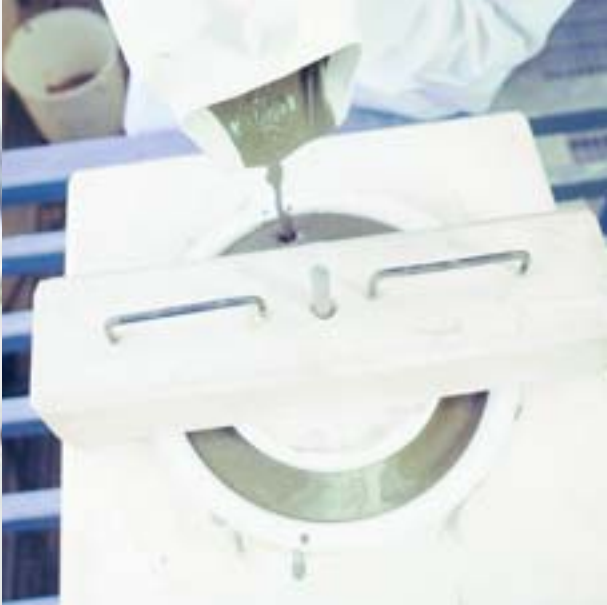

L'ELEGANZA SU MISURA

ELEGANCE CUSTOM-MADE



...anche le piccole cose fanno poesia: al ristorante "Balena", di Chicago, la sospensione "Le Ciotole" trova la location per esprimerla!

...also little things make poetry: in the restaurant "Balena", in Chicago, the suspension "Le Ciotole" is the suitable location to express it!



Antica Osteria "Al Baccaro": sotto al portico che porta alla bella piazza di Asolo si trova questo locale tipico dove gli articoli della linea "Tesa" trovano la loro corretta collocazione. Queste lampade enfatizzano lo stile della location e il suo carattere familiare.

Antique Osteria "Al Baccaro" under the portico leading to the beautiful square of Asolo is the typical place where line "Tesa" articles find their proper place. These lamps emphasize the style of the location and its family character.



I coordinati / Ensemble

page 12



linea Tesa
page 14



linea Piega
page 18



linea Delft
page 22



linea Bilancia sosp. / pend.
page 24



linea Laguna
page 32



linea Duse
page 36



linea Postiglione
page 40



linea Tenda
page 42



linea Provenza
page 44



linea Caracoi
page 46



linea Torcio
page 50



linea Baracca
page 52



linea Studio
page 54



linea Barchessa
page 56



linea Mansarda
page 57



linea Funnel
page 58



linea Farmacia
page 62



linea Tosca
page 66



linea Mizar
page 70



linea Isola
page 72



linea Polare
page 74



linea Le Macine
page 78



linea Le Ciotole
page 82



linea Le Ninfee
page 84



linea I Narcisi
page 86

Applique e plafoniere / Wall and ceiling lamps

page 88



linea Lagazuoi
page 90



linea 5 Torri
page 91



linea Tofane
page 92



linea Alpe di Sennes
page 94



linea Moiazza
page 95



linea Capaeònga
page 96



linea Bòsega
page 98



linea Allegro
page 100



linea Raggio
page 102



linea Glamour
page 104



linea Luna
page 106



linea Elisse
page 108



linea Preludio
page 110



linea Cappe
page 112



linea Andromeda
page 116



linea Mirfak
page 117



linea Quaranta
page 118



linea Orologi
page 120

Led inside

page 121



linea Bachata B1
page 122



linea Bachata B2
page 124



linea Bachata B3
page 126



linea Samba
page 128



linea Milonga
page 132



linea Tango
page 134

Impianto a treccia / Braid system

page 138



linea Castore
page 144



linea Polluce
page 148



linea Antares
page 150



linea Sirio
page 152



linea Rigel
page 154



linea Bellatrix
page 156



linea Meissa
page 158



linea Schengen
page 161



linea Acquario
page 162



linea Mimosa
page 170



linea Pleiadi
page 172

I COORDINATI ENSEMBLE

Un'illuminazione ben concepita, che favorisca il benessere e l'armonia di chi ne fruisce, è una scelta di carattere culturale che l'azienda ha già sposato da diversi anni e che vuole mantenere viva con proposte sempre nuove.

A well-designed lighting, which promotes the well-being and harmony of its users, is the choice of cultural nature that company has a long time already done and that wants to keep up with new proposals.

LINEA
Tesa

Serie di saliscendi, sospensioni ed applique in ceramica bianca, filo colorato o decorata a mano. Queste soluzioni, perfette in un ingresso o appese sopra ad un tavolo, donano all'ambiente una luce calda ed avvolgente. Gli articoli possono essere corredati con accessori di nostra produzione, da ordinare a parte, presenti da pag. 144 a pag. 183 del catalogo.

Series of pendants, pendants with counterweight and sconces made of white glazed, coloured line or decorated ceramic hand-made. These solutions, perfect hung above a table or in a hall, grace the room with warm, enveloping light. Fixtures can be combined with the accessories visible from page 144 to page 183 of the catalogue and to be ordered separately.



Art. 120.118

Art. 115.313
Art. LAR.138.02
Art. LAR.131.00





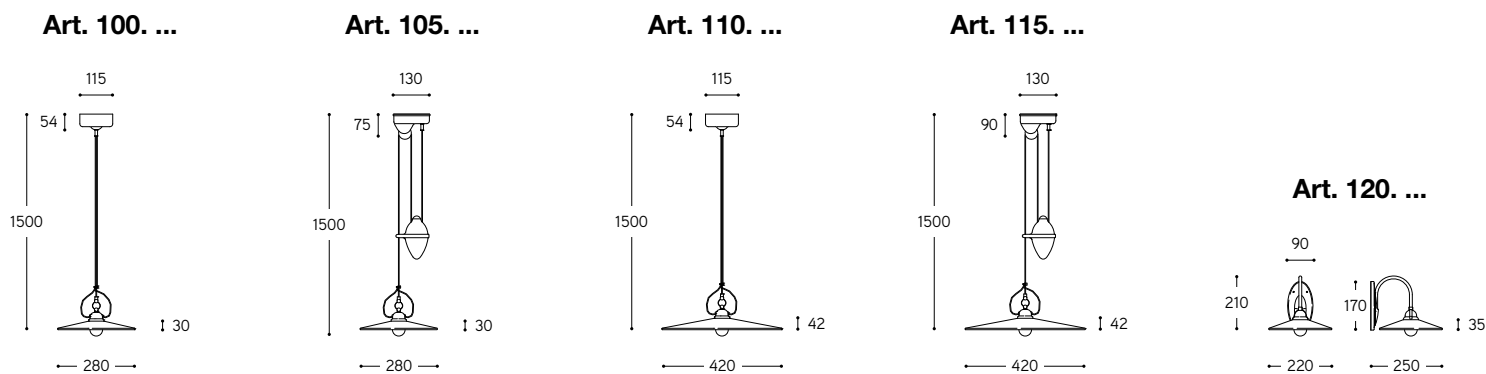

ARTICOLO ITEM	DESCRIZIONE DESCRIPTION	ATTACCO SOCKET	POTENZA POWER	PESO GR. WEIGHT GR.	VOL. IN M ³ VOL. IN M ³	PEZZI IMBALLO OUTER BOX	FASCIA PREZZO PRICE RANGE
Bianca / White							
100	Sospensione / Pendant	E27	70W	2.380	0,04	1	B38
105	Saliscendi / Pendant with counterweight	E27	70W	4.680	0,06	1	B58
110	Sospensione / Pendant	E27	70W	3.460	0,06	1	B49
115	Saliscendi / Pendant with counterweight	E27	70W	7.740	0,08	1	B77
120	Applique / Wall lamp	E27	42W	1.700	0,03	1	B43
Fili colorati / Coloured lines (*)							
100. ...	Sospensione / Pendant	E27	70W	2.380	0,04	1	B39
105. ...	Saliscendi / Pendant with counterweight	E27	70W	4.680	0,06	1	B62
110. ...	Sospensione / Pendant	E27	70W	3.460	0,06	1	B52
115. ...	Saliscendi / Pendant with counterweight	E27	70W	7.740	0,08	1	B81
120. ...	Applique / Wall lamp	E27	42W	1.700	0,03	1	B47
Decorata / Decorated (**)							
100. ...	Sospensione / Pendant	E27	70W	2.380	0,04	1	B45
105. ...	Saliscendi / Pendant with counterweight	E27	70W	4.680	0,06	1	B68
110. ...	Sospensione / Pendant	E27	70W	3.460	0,06	1	B64
115. ...	Saliscendi / Pendant with counterweight	E27	70W	7.740	0,08	1	B86
120. ...	Applique / Wall lamp	E27	42W	1.700	0,03	1	B52

CE IP20

(*) ... **FR** = Filo rosso / Red line
 ... **FM** = Filo marrone / Brown line
 ... **FA** = Filo ramina / Green line
 ... **FB** = Filo blu / Blue line
 ... **FO** = Filo arancio / Orange line

(**) ... **01** = Delft blu / Delft
 ... **05** = Vite / Grapevine
 ... **06** = Anemone / Anemone
 ... **07/V** = Greca in verde / Green greek fret
 ... **08/B** = Greca in blu / Blue greek fret
 ... **35** = Primavera blu / Blue spring
 ... **38** = Bordo verde / Green border

... **116** = Edera blu / Blue ivy
 ... **117** = Edera rossa / Red ivy
 ... **118** = Edera verde / Green ivy
 ... **313** = Foglie / Leaf
 ... **412** = Tulipani / Tulip
 ... **IB** = Intreccio blu / Blue intertwine

I Fili colorati e i Decori sono illustrati a pag. 184-185
 See Coloured lines and Decorations on page 184-185

LINEA Piega

Serie di saliscendi, sospensioni ed applique in ceramica bianca o con filo colorato. Queste soluzioni, perfette in un ingresso o appese sopra ad un tavolo, donano all'ambiente una luce calda ed avvolgente. Gli articoli possono essere corredati con accessori di nostra produzione, da ordinare a parte, presenti da pag. 144 a pag. 183 del catalogo.

Series of pendants, pendants with counterweight and sconces made of white glazed or coloured line ceramic. These solutions, perfect hung above a table or in a hall, grace the room with warm, enveloping light. Fixtures can be combined with the accessories visible from page 144 to page 183 of the catalogue and to be ordered separately.



Art. 220.FR

Art. 215.FB
Art. LAR.138.02
Art. LAR.131.00





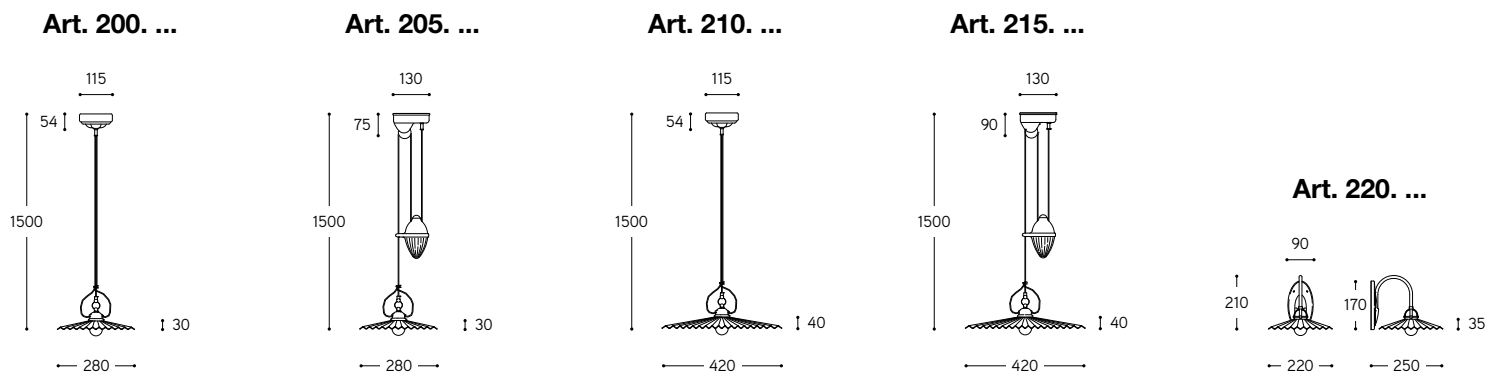

ARTICOLO ITEM	DESCRIZIONE DESCRIPTION	ATTACCO SOCKET	POTENZA POWER	PESO GR. WEIGHT GR.	VOL. IN M ³ VOL. IN M ³	PEZZI IMBALLO OUTER BOX	FASCIA PREZZO PRICE RANGE
Bianca / White							
200	Sospensione / Pendant	E27	70W	2.380	0,04	1	B38
205	Saliscendi / Pendant with counterweight	E27	70W	4.730	0,06	1	B58
210	Sospensione / Pendant	E27	70W	3.940	0,06	1	B50
215	Saliscendi / Pendant with counterweight	E27	70W	8.000	0,08	1	B78
220	Applique / Wall lamp	E27	42W	1.760	0,03	1	B43

Fili colorati / Coloured lines (*)

200. ...	Sospensione / Pendant	E27	70W	2.380	0,04	1	B39
205. ...	Saliscendi / Pendant with counterweight	E27	70W	4.730	0,06	1	B62
210. ...	Sospensione / Pendant	E27	70W	3.940	0,06	1	B54
215. ...	Saliscendi / Pendant with counterweight	E27	70W	8.000	0,08	1	B82
220. ...	Applique / Wall lamp	E27	42W	1.760	0,03	1	B46



(*) ... **FR** = Filo rosso / Red line
 ... **FM** = Filo marrone / Brown line
 ... **FA** = Filo ramina / Green line
 ... **FB** = Filo blu / Blue line
 ... **FO** = Filo arancio / Orange line

LINEA Delft

Serie di saliscendi, sospensioni ed applique in ceramica bianca o decorata a mano. Queste soluzioni, perfette in un ingresso o appese sopra ad un tavolo, donano all'ambiente una luce calda ed avvolgente. Gli articoli possono essere corredati con accessori di nostra produzione, da ordinare a parte, presenti da pag. 144 a pag. 183 del catalogo.

Series of pendants, pendants with counterweight and sconces made of white glazed or decorated ceramic hand-made. These solutions, perfect hung above a table or in a hall, grace the room with warm, enveloping light. Fixtures can be combined with the accessories visible from page 144 to page 183 of the catalogue and to be ordered separately.



Art. 310. ...

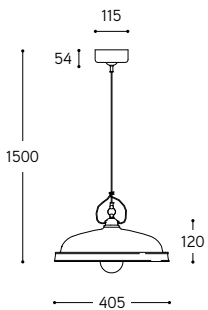

Art. 315. ...

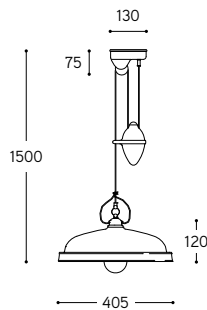

Art. 320.05

Art. 320. ...

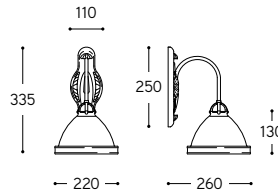

ARTICOLO ITEM	DESCRIZIONE DESCRIPTION	ATTACCO SOCKET	POTENZA POWER	PESO GR. WEIGHT GR.	VOL. IN M³ VOL. IN M³	PEZZI IMBALLO OUTER BOX	FASCIA PREZZO PRICE RANGE
Bianca / White							
310	Sospensione / Pendant	E27	70W	4.150	0,06	1	B44
315	Saliscendi / Pendant with counterweight	E27	70W	9.500	0,08	1	B67
320	Applique / Wall lamp	E27	42W	2.290	0,03	1	B44
Decorata / Decorated (*)							
310. ...	Sospensione / Pendant	E27	70W	4.150	0,06	1	B55
315. ...	Saliscendi / Pendant with counterweight	E27	70W	9.500	0,08	1	B79
320. ...	Applique / Wall lamp	E27	42W	2.290	0,03	1	B50

CE IP20

(*) ... **01** = Delft blu / Delft
 ... **05** = Vite / Grapevine
 ... **06** = Anemone / Anemone
 ... **07/V** = Greca in verde / Green greek fret
 ... **08/B** = Greca in blu / Blue greek fret
 ... **35** = Primavera blu / Blue spring
 ... **38** = Bordo verde / Green border

... **116** = Edera blu / Blue ivy
 ... **117** = Edera rossa / Red ivy
 ... **118** = Edera verde / Green ivy
 ... **313** = Foglie / Leaf
 ... **412** = Tulipani / Tulip
 ... **IB** = Intreccio blu / Blue intertwine

I Decorati sono illustrati a pag. 184-185
 See Decorations on page 184-185

Art. 315.01
Art. LAR.138.02
Art. LAR.131.00



LINEA

Bilancia

sospensioni e saliscendi
pendants and pendants with counterweight

Serie di saliscendi e sospensioni in ceramica bianca, filo colorato, in ceramica "cotto" con interno bianco o in ceramica decorata a mano. Queste soluzioni, perfette in un ingresso o appese sopra ad un tavolo, donano all'ambiente una luce calda ed avvolgente. Gli articoli possono essere corredati con accessori di nostra produzione, da ordinare a parte, presenti da pag. 144 a pag. 183 del catalogo.

Series of pendants made of white ceramic, "cotto" ceramic with white glazed inside, coloured line or decorated ceramic hand-made. These solutions, perfect hung above a table or in a hall, grace the room with warm, enveloping light. Fixtures can be combined with the accessories visible from page 144 to page 183 of the catalogue and to be ordered separately.



Art. 815.CB
Art. LAR.138.02
Art. LAR.131.00



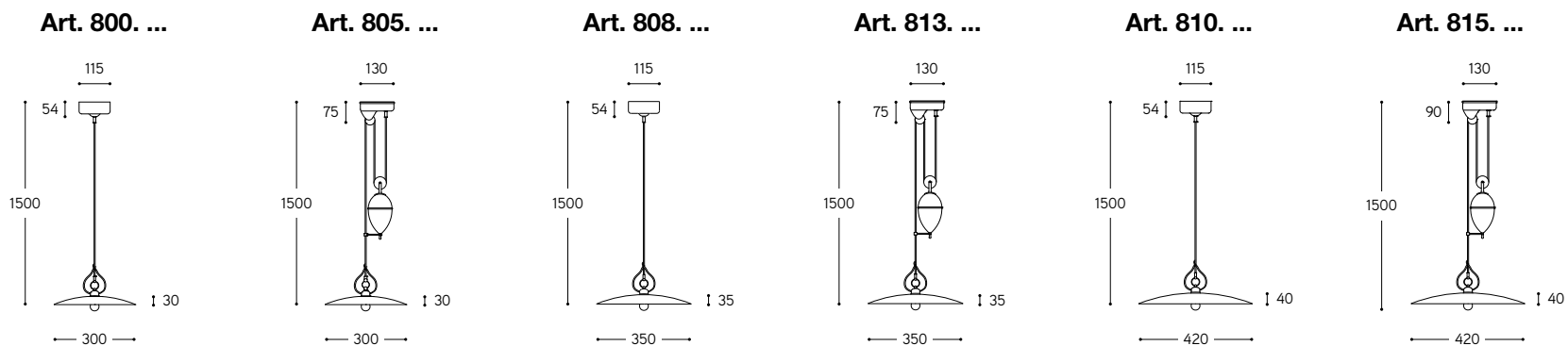

ARTICOLO ITEM	DESCRIZIONE DESCRIPTION	ATTACCO SOCKET	POTENZA POWER	PESO GR. WEIGHT GR.	VOL. IN M ³ VOL. IN M ³	PEZZI IMBALLO OUTER BOX	FASCIA PREZZO PRICE RANGE
Bianca / White							
800	Sospensione / Pendant	E27	70W	2.520	0,04	1	B40
805	Saliscendi / Pendant with counterweight	E27	70W	5.000	0,06	1	B61
808	Sospensione / Pendant	E27	70W	3.340	0,06	1	B45
813	Saliscendi / Pendant with counterweight	E27	70W	6.000	0,06	1	B68
810	Sospensione / Pendant	E27	70W	3.700	0,06	1	B50
815	Saliscendi / Pendant with counterweight	E27	70W	7.360	0,08	1	B78
Fili colorati / Coloured lines (*)							
800. ...	Sospensione / Pendant	E27	70W	2.520	0,04	1	B43
805. ...	Saliscendi / Pendant with counterweight	E27	70W	5.000	0,06	1	B65
808. ...	Sospensione / Pendant	E27	70W	3.340	0,06	1	B48
813. ...	Saliscendi / Pendant with counterweight	E27	70W	6.000	0,06	1	B73
810. ...	Sospensione / Pendant	E27	70W	3.700	0,06	1	B52
815. ...	Saliscendi / Pendant with counterweight	E27	70W	7.360	0,08	1	B82
Decorata / Decorated (**)							
800. ...	Sospensione / Pendant	E27	70W	2.520	0,04	1	B49
805. ...	Saliscendi / Pendant with counterweight	E27	70W	5.000	0,06	1	B68
808. ...	Sospensione / Pendant	E27	70W	3.340	0,06	1	B55
813. ...	Saliscendi / Pendant with counterweight	E27	70W	6.000	0,06	1	B74
810. ...	Sospensione / Pendant	E27	70W	3.700	0,06	1	B65
815. ...	Saliscendi / Pendant with counterweight	E27	70W	7.360	0,08	1	B86
Cotto con interno bianco / Cotto/White glazed inside							
800.CB	Sospensione / Pendant	E27	70W	2.520	0,04	1	B43
805.CB	Saliscendi / Pendant with counterweight	E27	70W	5.000	0,06	1	B66
808.CB	Sospensione / Pendant	E27	70W	3.340	0,06	1	B50
813.CB	Saliscendi / Pendant with counterweight	E27	70W	6.000	0,06	1	B74
810.CB	Sospensione / Pendant	E27	70W	3.700	0,06	1	B55
815.CB	Saliscendi / Pendant with counterweight	E27	70W	7.360	0,08	1	B85

CE IP20

(*) ... **FR** = Filo rosso / Red line
 ... **FM** = Filo marrone / Brown line
 ... **FA** = Filo ramina / Green line
 ... **FB** = Filo blu / Blue line
 ... **FO** = Filo arancio / Orange line

(**) ... **01** = Delft blu / Delft
 ... **05** = Vite / Grapevine
 ... **06** = Anemone / Anemone
 ... **07/V** = Greca in verde / Green greek fret
 ... **08/B** = Greca in blu / Blue greek fret
 ... **35** = Primavera blu / Blue spring
 ... **38** = Bordo verde / Green border

... **116** = Edera blu / Blue ivy
 ... **117** = Edera rossa / Red ivy
 ... **118** = Edera verde / Green ivy
 ... **313** = Foglie / Leaf
 ... **412** = Tulipani / Tulip
 ... **IB** = Intreccio blu / Blue intertwine

I Fili colorati e i Decorati sono illustrati a pag. 184-185
 See Coloured lines and Decorations on page 184-185

Art. 41.820
Art. LAR.134.B

LINEA

Bilancia

plafoniera/applique
ceiling/wall lamp

Plafoniera e applique disponibili nelle versioni in ceramica bianca, ceramica decorata o filo colorato, ceramica "cotto" o "cotto" con interno bianco. I riflettori possono essere di due dimensioni da specificare al momento dell'ordine. Queste soluzioni, perfette in un ingresso o sopra ad un tavolo, donano all'ambiente una luce calda ed avvolgente. Gli articoli possono essere corredati con accessori di nostra produzione, da ordinare a parte, presenti da pag. 144 a pag. 183 del catalogo.

Ceiling and wall lamp available in white glazed ceramic, coloured line or decorated ceramic and "cotto" ceramic also in white glazed inside version. These solutions, perfect above a table or in a hall, grace the room with warm, enveloping light. The fixture can be combined with the accessories visible from page 144 to page 183 of the catalogue and to be ordered separately.



Art. 823.06
Art. LAR.134.B

Art. 41.823.CB
Art. LAR.134.B





Art. 41.820. ...

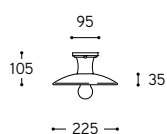

Art. 41.823. ...

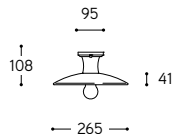

Art. 820. ...

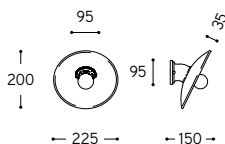

Art. 823. ...

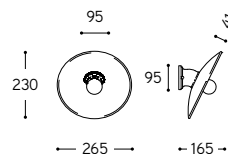

ARTICOLO ITEM	DESCRIZIONE DESCRIPTION	ATTACCO SOCKET	POTENZA POWER	PESO GR. WEIGHT GR.	VOL. IN M ³ VOL. IN M ³	PEZZI IMBALLO OUTER BOX	FASCIA PREZZO PRICE RANGE
------------------	----------------------------	-------------------	------------------	------------------------	--	----------------------------	------------------------------

Bianca / White

41.820	Plafoniera / Ceiling lamp	E27	42W	1.480	0,02	1	B37
41.823	Plafoniera / Ceiling lamp	E27	42W	1.500	0,03	1	B39
820	Applique / Wall lamp	E27	42W	1.440	0,02	1	B37
823	Applique / Wall lamp	E27	42W	1.460	0,03	1	B39

Fili colorati / Coloured lines (*)

41.820. ...	Plafoniera / Ceiling lamp	E27	42W	1.480	0,02	1	B39
41.823. ...	Plafoniera / Ceiling lamp	E27	42W	1.500	0,03	1	B42
820. ...	Applique / Wall lamp	E27	42W	1.440	0,02	1	B39
823. ...	Applique / Wall lamp	E27	42W	1.460	0,03	1	B42

Decorata / Decorated (**)

41.820. ...	Plafoniera / Ceiling lamp	E27	42W	1.480	0,02	1	B42
41.823. ...	Plafoniera / Ceiling lamp	E27	42W	1.500	0,03	1	B46
820. ...	Applique / Wall lamp	E27	42W	1.440	0,02	1	B42
823. ...	Applique / Wall lamp	E27	42W	1.460	0,03	1	B46

Cotto / Cotto

41.820.C	Plafoniera / Ceiling lamp	E27	42W	1.480	0,02	1	B37
41.823.C	Plafoniera / Ceiling lamp	E27	42W	1.500	0,03	1	B39
820.C	Applique / Wall lamp	E27	42W	1.440	0,02	1	B37
823.C	Applique / Wall lamp	E27	42W	1.460	0,03	1	B39

Cotto con interno bianco / Cotto/White glazed inside

41.820.CB	Plafoniera / Ceiling lamp	E27	42W	1.480	0,02	1	B39
41.823.CB	Plafoniera / Ceiling lamp	E27	42W	1.500	0,03	1	B42
820.CB	Applique / Wall lamp	E27	42W	1.440	0,02	1	B39
823.CB	Applique / Wall lamp	E27	42W	1.460	0,03	1	B42



(*) ... FR = Filo rosso / Red line
 ... FM = Filo marrone / Brown line
 ... FA = Filo ramina / Green line
 ... FB = Filo blu / Blue line
 ... FO = Filo arancio / Orange line

(**) ... 01 = Delft blu / Delft
 ... 05 = Vite / Grapevine
 ... 06 = Anemone / Anemone
 ... 07/V = Greca in verde / Green greek fret
 ... 08/B = Greca in blu / Blue greek fret
 ... 35 = Primavera blu / Blue spring
 ... 38 = Bordo verde / Green border

... 116 = Edera blu / Blue ivy
 ... 117 = Edera rossa / Red ivy
 ... 118 = Edera verde / Green ivy
 ... 313 = Foglie / Leaf
 ... 412 = Tulipani / Tulip
 ... IB = Intreccio blu / Blue intertwine

I Fili colorati e i Decorati sono illustrati a pag. 184-185
 See Coloured lines and Decorations on page 184-185

LINEA Laguna

Serie di saliscendi, sospensioni ed applique in ceramica smaltata oca o bianca. Queste soluzioni, perfette in un ingresso o appese sopra ad un tavolo, donano all'ambiente una luce calda ed avvolgente.

Gli articoli possono essere corredati con accessori di nostra produzione, da ordinare a parte, presenti da pag. 144 a pag. 183 del catalogo.

Series of pendants, pendants with counterweight and sconces made of white or ocher glazed ceramic. These solutions, perfect hung above a table or in a hall, grace the room with warm, enveloping light.

Fixtures can be combined with the accessories visible from page 144 to page 183 of the catalogue and to be ordered separately.



Art. 2020.22







Art. 2022.22

Art. 2010

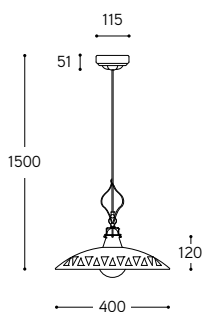

Art. 2015

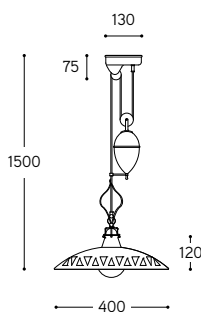

Art. 2020

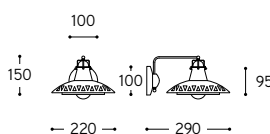

Art. 2022

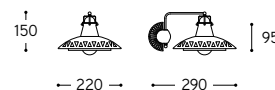

ARTICOLO ITEM	DESCRIZIONE DESCRIPTION	ATTACCO SOCKET	POTENZA POWER	PESO GR. WEIGHT GR.	VOL. IN M ³ VOL. IN M ³	PEZZI IMBALLO OUTER BOX	FASCIA PREZZO PRICE RANGE
Bianca / White							
2010	Sospensione / Pendant	E27	70W	4.240	0,08	1	B63
2015	Saliscendi / Pendant with counterweight	E27	70W	7.860	0,08	1	B87
2020	Applique / Wall lamp	E27	42W	1.810	0,03	1	B56
2022	Applique spigolo / Corner wall lamp	E27	42W	1.810	0,03	1	B57
Ocra / Ochre							
2010.22	Sospensione / Pendant	E27	70W	4.240	0,08	1	B67
2015.22	Saliscendi / Pendant with counterweight	E27	70W	7.860	0,08	1	B89
2020.22	Applique / Wall lamp	E27	42W	1.810	0,03	1	B59
2022.22	Applique spigolo / Corner wall lamp	E27	42W	1.810	0,03	1	B60

LINEA
Duse

Serie di saliscendi, sospensioni ed applique in ceramica bianca o in ceramica "cotto" con interno bianco. Queste soluzioni, perfette in un ingresso o appese sopra ad un tavolo, donano all'ambiente una luce calda ed avvolgente. Gli articoli possono essere corredati con accessori di nostra produzione, da ordinare a parte, presenti da pag. 144 a pag. 183 del catalogo.

Series of pendants, pendants with counterweight and sconces made of white ceramic or "cotto" ceramic with white glazed inside. These solutions, perfect hung above a table or in a hall, grace the room with warm, enveloping light. Fixtures can be combined with the accessories visible from page 144 to page 183 of the catalogue and to be ordered separately.



Art. 2120.CB





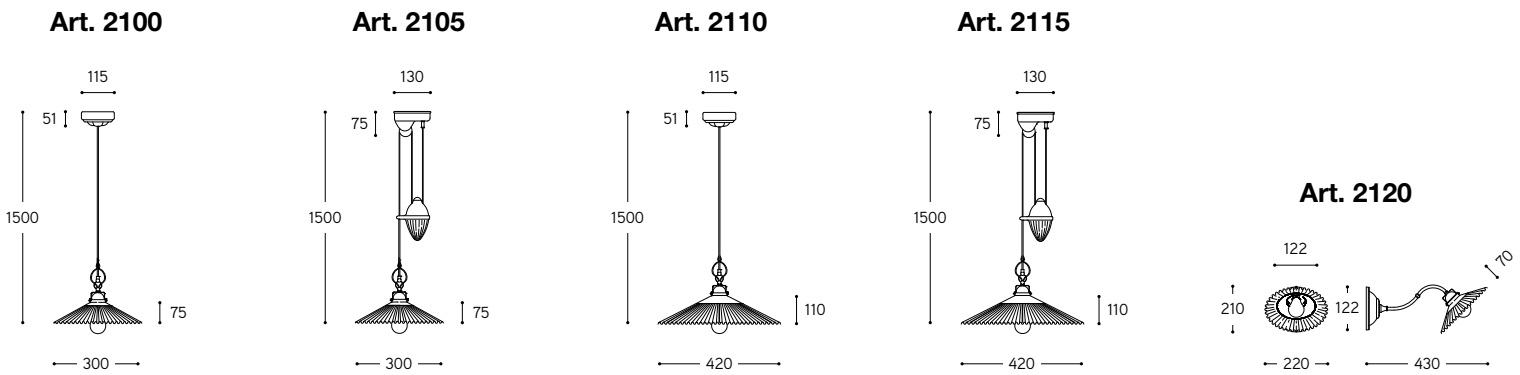

ARTICOLO ITEM	DESCRIZIONE DESCRIPTION	ATTACCO SOCKET	POTENZA POWER	PESO GR. WEIGHT GR.	VOL. IN M ³ VOL. IN M ³	PEZZI IMBALLO OUTER BOX	FASCIA PREZZO PRICE RANGE
Bianca / White							
2100	Sospensione / Pendant	E27	70W	2.900	0,04	1	B43
2105	Saliscendi / Pendant with counterweight	E27	70W	5.450	0,06	1	B65
2110	Sospensione / Pendant	E27	70W	4.200	0,06	1	B55
2115	Saliscendi / Pendant with counterweight	E27	70W	8.000	0,08	1	B80
2120	Applique / Wall lamp	E27	42W	1.820	0,03	1	B46

Cotto smaltato bianco / Cotto/White glazed

2100.CB	Sospensione / Pendant	E27	70W	2.900	0,04	1	B46
2105.CB	Saliscendi / Pendant with counterweight	E27	70W	5.450	0,06	1	B67
2110.CB	Sospensione / Pendant	E27	70W	4.200	0,06	1	B59
2115.CB	Saliscendi / Pendant with counterweight	E27	70W	8.000	0,08	1	B85
2120.CB	Applique / Wall lamp	E27	42W	1.820	0,03	1	B50

LINEA Postiglione

Serie di saliscendi, sospensioni ed applique in ottone anticato e ceramica bianca. Queste soluzioni, perfette in un ingresso o appese sopra ad un tavolo, donano all'ambiente una luce calda ed avvolgente. Gli articoli possono essere corredati con accessori di nostra produzione, da ordinare a parte, presenti da pag. 144 a pag. 183 del catalogo.

Series of pendants, pendants with counterweight and sconces made of brass and white glazed ceramic. These solutions, perfect hung above a table or in a hall, grace the room with warm, enveloping light. Fixtures can be combined with the accessories visible from page 144 to page 183 of the catalogue and to be ordered separately.



Art. 3620

Art. 3610

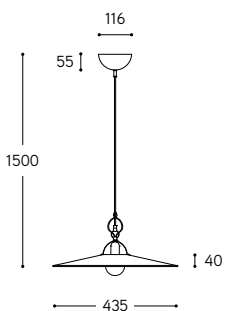

Art. 3615

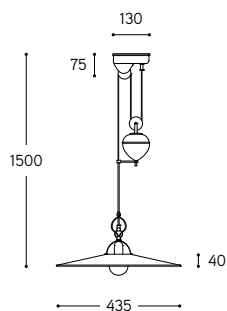

Art. 3620

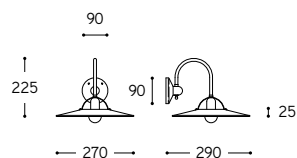

ARTICOLO ITEM	DESCRIZIONE DESCRIPTION	ATTACCO SOCKET	POTENZA POWER	PESO GR. WEIGHT GR.	VOL. IN M ³ VOL. IN M ³	PEZZI IMBALLO OUTER BOX	FASCIA PREZZO PRICE RANGE
3610	Sospensione / Pendant	E27	70W	3.300	0,06	1	B67
3615	Saliscendi / Pendant with counterweight	E27	70W	7.000	0,08	1	B89
3620	Applique / Wall lamp	E27	42W	1.800	0,03	1	B59



LINEA
Tenda

Serie di saliscendi, sospensioni ed applique in ottone, vetro e ceramica bianca. Queste soluzioni, perfette in un ingresso o appese sopra ad un tavolo, donano all'ambiente una luce calda ed avvolgente. Gli articoli possono essere corredati con accessori di nostra produzione, da ordinare a parte, presenti da pag. 144 a pag. 183 del catalogo.

Series of pendants, pendants with counterweight and sconces made of glass and white glazed ceramic. These solutions, perfect hung above a table or in a hall, grace the room with warm, enveloping light. Fixtures can be combined with the accessories visible from page 144 to page 183 of the catalogue and to be ordered separately.



Art. 3920

Art. 3910

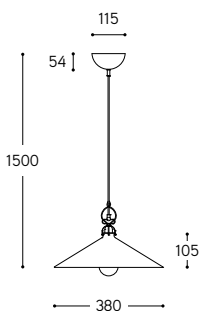

Art. 3915

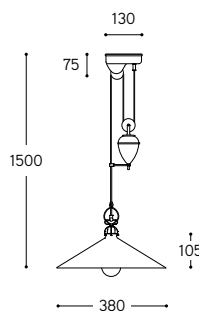

Art. 3920

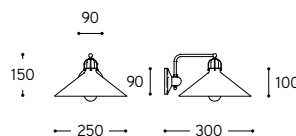

ARTICOLO ITEM	DESCRIZIONE DESCRIPTION	ATTACCO SOCKET	POTENZA POWER	PESO GR. WEIGHT GR.	VOL. IN M ³ VOL. IN M ³	PEZZI IMBALLO OUTER BOX	FASCIA PREZZO PRICE RANGE
3910	Sospensione / Pendant	E27	70W	3.340	0,06	1	B57
3915	Saliscendi / Pendant with counterweight	E27	70W	6.750	0,08	1	B82
3920	Applique / Wall lamp	E27	42W	1.800	0,03	1	B46



LINEA

Provenza

Serie di saliscendi, sospensioni ed applique in ceramica bianca o decorata a mano. Queste soluzioni, perfette in un ingresso o appese sopra ad un tavolo, donano all'ambiente una luce calda ed avvolgente. Gli articoli possono essere corredati con accessori di nostra produzione, da ordinare a parte, presenti da pag. 144 a pag. 183 del catalogo.

Series of pendants, pendants with counterweight and sconces made of white glazed or decorated ceramic hand-made. These solutions, perfect hung above a table or in a hall, grace the room with warm, enveloping light. Fixtures can be combined with the accessories visible from page 144 to page 183 of the catalogue and to be ordered separately.



Art. 9915.IB
Art. LAR.138.02
Art. LAR.131.00



Art. 9920.IB

Art. 9910. ...

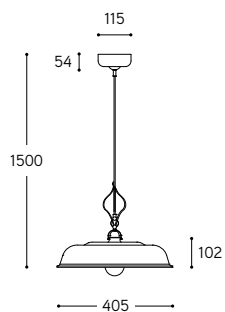

Art. 9915. ...

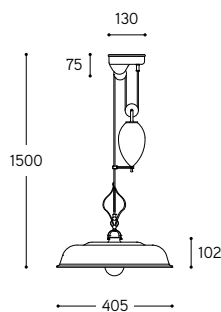

Art. 9920. ...

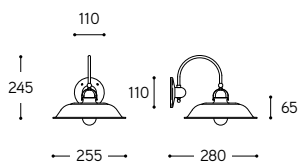

ARTICOLO ITEM	DESCRIZIONE DESCRIPTION	ATTACCO SOCKET	POTENZA POWER	PESO GR. WEIGHT GR.	VOL. IN M³ VOL. IN M³	PEZZI IMBALLO OUTER BOX	FASCIA PREZZO PRICE RANGE
Bianca / White							
9910	Sospensione / Pendant	E27	70W	3.730	0,06	1	B56
9915	Saliscendi / Pendant with counterweight	E27	70W	8.200	0,08	1	B80
9920	Applique / Wall lamp	E27	42W	2.000	0,03	1	B46
Decorata / Decorated (*)							
9910. ...	Sospensione / Pendant	E27	70W	3.730	0,06	1	B64
9915. ...	Saliscendi / Pendant with counterweight	E27	70W	8.200	0,08	1	B87
9920. ...	Applique / Wall lamp	E27	42W	2.000	0,03	1	B51

CE IP20

- (*) ... 01 = Delft blu / Delft
 ... 05 = Vite / Grapevine
 ... 06 = Anemone / Anemone
 ... 07/V = Greca in verde / Green greek fret
 ... 08/B = Greca in blu / Blue greek fret
 ... 35 = Primavera blu / Blue spring
 ... 38 = Bordo verde / Green border

- ... 116 = Edera blu / Blue ivy
 ... 117 = Edera rossa / Red ivy
 ... 118 = Edera verde / Green ivy
 ... 313 = Foglie / Leaf
 ... 412 = Tulipani / Tulip
 ... IB = Intreccio blu / Blue intertwine

I Decorati sono illustrati a pag. 184-185
 See Decorations on page 184-185

Art. 9122.IB.P

LINEA
Caracoi

Serie composta da sospensioni ed applique con diffusore in vetro bianco latte lucido, struttura in ottone anticato e particolari in ceramica bianca o decorata. La sospensione è regolabile in altezza al momento dell'installazione. Queste soluzioni, perfette in un ingresso o appese sopra ad un tavolo, donano all'ambiente una luce calda ed avvolgente.

Series of pendants and sconces made of aged brass structure, white or decorated ceramic details and shiny white-milk diffuser. The pendant height is adjustable at installation time. These solutions, perfect hung above a table or in a hall, grace the room with warm, enveloping light.



Art. 9120.IB.L





Art. 9132. ...

Art. 9133. ...

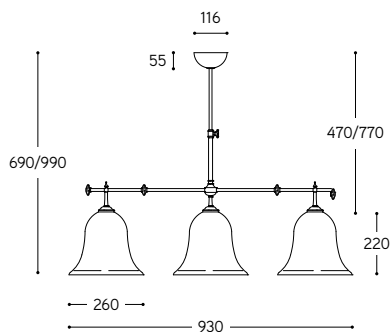
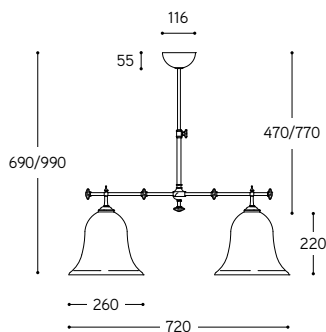

Art. 9120. ...

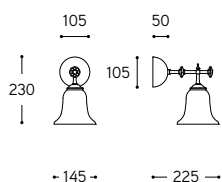

Art. 9122. ...

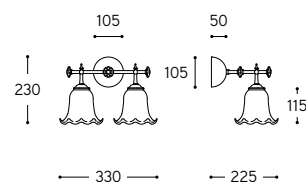

ARTICOLO ITEM	DESCRIZIONE DESCRIPTION	VETRO GLASS	ATTACCO SOCKET	POTENZA POWER	PESO GR. WEIGHT GR.	VOL. IN M ³ VOL. IN M ³	PEZZI IMBALLO OUTER BOX	FASCIA PREZZO PRICE RANGE
Bianca / White								
9132.L	Sospensione 2 luci / 2 lights pendant	liscio / smooth	E27	2x42W	10.160	0,26	1	B108
9132.P		plissé / plissé	E27	2x42W	10.160	0,26	1	B108
9133.L	Sospensione 3 luci / 3 lights pendant	liscio / smooth	E27	3x42W	11.500	0,38	1	B123
9133.P		plissé / plissé	E27	3x42W	11.500	0,38	1	B123
9120.L	Applique 1 luce / 1 light wall lamp	liscio / smooth	E27	42W	1.540	0,02	1	B50
9120.P		plissé / plissé	E27	42W	1.540	0,02	1	B50
9122.L	Applique 2 luci / 2 lights wall lamp	liscio / smooth	E27	2x42W	2.650	0,06	1	B68
9122.P		plissé / plissé	E27	2x42W	2.650	0,06	1	B68

Decoro intreccio blu / Blue intertwine decoration

9132.IB.L	Sospensione 2 luci / 2 lights pendant	liscio / smooth	E27	2x42W	10.160	0,26	1	B116
9132.IB.P		plissé / plissé	E27	2x42W	10.160	0,26	1	B116
9133.IB.L	Sospensione 3 luci / 3 lights pendant	liscio / smooth	E27	3x42W	11.500	0,38	1	B131
9133.IB.P		plissé / plissé	E27	3x42W	11.500	0,38	1	B131
9120.IB.L	Applique 1 luce / 1 light wall lamp	liscio / smooth	E27	42W	1.540	0,02	1	B55
9120.IB.P		plissé / plissé	E27	42W	1.540	0,02	1	B55
9122.IB.L	Applique 2 luci / 2 lights wall lamp	liscio / smooth	E27	2x42W	2.650	0,06	1	B77
9122.IB.P		plissé / plissé	E27	2x42W	2.650	0,06	1	B77

Art. 9421.IB.P

LINEA
Torcio

Serie di applique ad uno o due luci, con base in ceramica bianca o decorata, bracci in ottone anticato e diffusore in vetro bianco latte lucido. Queste soluzioni donano all'ambiente una luce calda ed avvolgente.

Series of single and double sconces made of aged brass arm, white or decorated ceramic base and shiny white-milk diffuser. These solutions grace the room with warm, enveloping light.



Art. 9422.IB.L

Art. 9421. ...

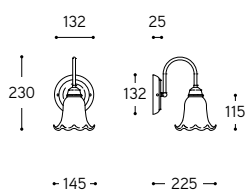

Art. 9422. ...

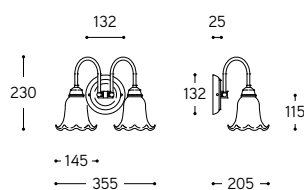

ARTICOLO ITEM	DESCRIZIONE DESCRIPTION	VETRO GLASS	ATTACCO SOCKET	POTENZA POWER	PESO GR. WEIGHT GR.	VOL. IN M ³ VOL. IN M ³	PEZZI IMBALLO OUTER BOX	FASCIA PREZZO PRICE RANGE
Bianca / White								
9421.L	Applique 1 luce / 1 light wall lamp	liscio / smooth	E27	42W	1.650	0,02	1	B49
9421.P		plissé / plissé	E27	42W	1.650	0,02	1	B49
9422.L	Applique 2 luci / 2 lights wall lamp	liscio / smooth	E27	2x42W	2.740	0,06	1	B72
9422.P		plissé / plissé	E27	2x42W	2.740	0,06	1	B72
Decoro intreccio blu / Blue intertwine decoration								
9421.IB.L	Applique 1 luce / 1 light wall lamp	liscio / smooth	E27	42W	1.650	0,02	1	B54
9421.IB.P		plissé / plissé	E27	42W	1.650	0,02	1	B54
9422.IB.L	Applique 2 luci / 2 lights wall lamp	liscio / smooth	E27	2x42W	2.740	0,06	1	B75
9422.IB.P		plissé / plissé	E27	2x42W	2.740	0,06	1	B75

CE IP20

Art. 41.9331.IB.P



LINEA
Baracca

Serie composta da applique e plafoniera ad una luce orientabile, con base in ceramica bianca o decorata, bracci in ottone anticato e diffusore in vetro bianco latte lucido. Queste soluzioni donano all'ambiente una luce calda ed avvolgente.

Series of single adjustable sconces and ceiling lamp made of aged brass arm, white or decorated ceramic base and shiny white-milk diffuser. These solutions grace the room with warm, enveloping light.



Art. 9351.IB.P

Art. 41.9331. ...

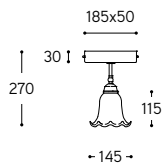

Art. 9351. ...

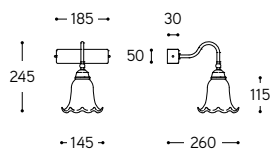

ARTICOLO ITEM	DESCRIZIONE DESCRIPTION	VETRO GLASS	ATTACCO SOCKET	POTENZA POWER	PESO GR. WEIGHT GR.	VOL. IN M ³ VOL. IN M ³	PEZZI IMBALLO OUTER BOX	FASCIA PREZZO PRICE RANGE
Bianca / White								
41.9331.L	Plafoniera / Ceiling lamp	liscio / smooth	E27	42W	1.420	0,02	1	B45
41.9331.P		plissé / plissé	E27	42W	1.420	0,02	1	B45
9351.L	Applique / Wall lamp	liscio / smooth	E27	42W	1.630	0,03	1	B50
9351.P		plissé / plissé	E27	42W	1.630	0,03	1	B50
Decoro intreccio blu / Blue intertwine decoration								
41.9331.IB.L	Plafoniera / Ceiling lamp	liscio / smooth	E27	42W	1.420	0,02	1	B49
41.9331.IB.P		plissé / plissé	E27	42W	1.420	0,02	1	B49
9351.IB.L	Applique / Wall lamp	liscio / smooth	E27	42W	1.630	0,03	1	B55
9351.IB.P		plissé / plissé	E27	42W	1.630	0,03	1	B55

CE IP20

LINEA
Studio

Serie di applique a luce orientabile, con base e riflettore in ceramica bianca o decorata, bracci in ottone anticato. Queste soluzioni donano all'ambiente una luce calda ed avvolgente.

Series of adjustable sconces made of aged brass arm, white or decorated ceramic base and shape. These solutions grace the room with warm, enveloping light.



Art. 9522.IB



Art. 9521.IB

Art. 9521. ...

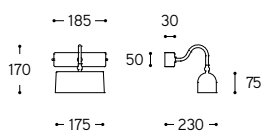

Art. 9522. ...

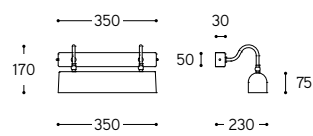

ARTICOLO ITEM	DESCRIZIONE DESCRIPTION	ATTACCO SOCKET	POTENZA POWER	PESO GR. WEIGHT GR.	VOL. IN M ³ VOL. IN M ³	PEZZI IMBALLO OUTER BOX	FASCIA PREZZO PRICE RANGE
Bianca / White							
9521	Applique 1 luce / 1 light wall lamp	E27	42W	1.780	0,03	1	B56
9522	Applique 2 luci / 2 lights wall lamp	E27	2x42W	2.930	0,06	1	B79
Decoro intreccio blu / Blue intertwine decoration							
9521.IB	Applique 1 luce / 1 light wall lamp	E27	42W	1.780	0,03	1	B63
9522.IB	Applique 2 luci / 2 lights wall lamp	E27	2x42W	2.930	0,06	1	B86

CE IP20

Art. 9611.IB.P

LINEA
Barchessa

Sospensione ad una luce orientabile, con diffusore in vetro bianco latte lucido, struttura in ottone anticato e particolari in ceramica bianca o decorata. Questa soluzione, perfetta in un ingresso o appesa sopra ad un tavolo, dona all'ambiente una luce calda ed avvolgente.

Pendant with adjustable joint, made in aged brass structure, white or decorated ceramic details and shiny white-milk diffuser. This solution, perfect hung above a table or in a hall, grace the room with warm, enveloping light.

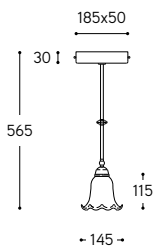

ARTICOLO ITEM	DESCRIZIONE DESCRIPTION	VETRO GLASS	ATTACCO SOCKET	POTENZA POWER	PESO GR. WEIGHT GR.	VOL. IN M ³ VOL. IN M ³	PEZZI IMBALLO OUTER BOX	FASCIA PREZZO PRICE RANGE
Bianca / White								
9611.L	Sospensione / Pendant	liscio / smooth	E27	42W	2.040	0,03	1	B58
9611.P		plissé / plissé	E27	42W	2.040	0,03	1	B58
Decoro intreccio blu / Blue intertwine decoration								
9611.IB.L	Sospensione / Pendant	liscio / smooth	E27	42W	2.040	0,03	1	B64
9611.IB.P		plissé / plissé	E27	42W	2.040	0,03	1	B64

Art. 41.9820.IB



LINEA
Mansarda

Plafoniera con base in ceramica bianca o decorata e diffusore in vetro bianco latte lucido. Questa soluzione, perfetta in un ingresso o appesa sopra ad un tavolo, dona all'ambiente una luce calda ed avvolgente.

Ceiling lamp made of white or decorated ceramic base and shiny white-milk diffuser. This solution, perfect hung above a table or in a hall, grace the room with warm, enveloping light.

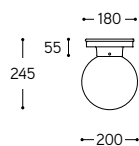

ARTICOLO ITEM	DESCRIZIONE DESCRIPTION	ATTACCO SOCKET	POTENZA POWER	PESO GR. WEIGHT GR.	VOL. IN M ³ VOL. IN M ³	PEZZI IMBALLO OUTER BOX	FASCIA PREZZO PRICE RANGE
41.9820 Bianco / White	Plafoniera / Ceiling lamp	E27	70W	2.480	0,04	1	B56
41.9820.IB Decoro intreccio blu / Blue intertwine dec.							B61

CE IP20

LINEA
Funnel

Lampade a sospensione disponibili nella versione in cemento (con finitura grigio scuro) o in cemento fibrato alleggerito (con finitura corten).

Pendants available in concrete version (concrete coloured finishing) or in lightweight fiber concrete (corten coloured finishing).







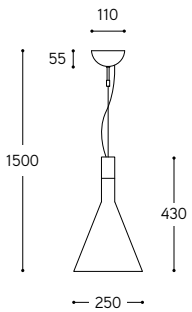

ARTICOLO ITEM	DESCRIZIONE DESCRIPTION	ATTACCO SOCKET	POTENZA POWER	PESO GR. WEIGHT GR.	VOL. IN M ³ VOL. IN M ³	FASCIA PREZZO PRICE RANGE
FUNNEL	Sospensione finitura corten / Corten finishing pendant	E27	23W PAR38 megaman	4.520	0,08	B90
FUNNEL/2	Sospensione in cemento / Cement pendant	E27	23W PAR38 megaman	4.520	0,08	B90

CE Ⓟ IP20 

LINEA

Farmacia

Serie di sospensioni ad una, due o tre luci, regolabili in altezza al momento dell'installazione, con asta e rosone in ottone anticato e diffusore in vetro bianco latte lucido.

I diffusori laterali delle versioni a 2 e 3 luci sono orientabili.

Queste soluzioni, perfette in un ingresso o appese sopra ad un tavolo, donano all'ambiente una luce calda ed avvolgente.

Series of one, two or three light pendants, height-adjustable at installation time, with aged brass rod and ceiling-rose, and shiny white-milk diffuser. Two or three light versions lateral diffusers can be adjusted. These solutions, perfect hung above a table or in a hall, grace the room with warm, enveloping light.







Art. 4600.2

Art. 4600.1

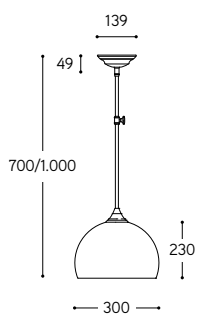

Art. 4600.2

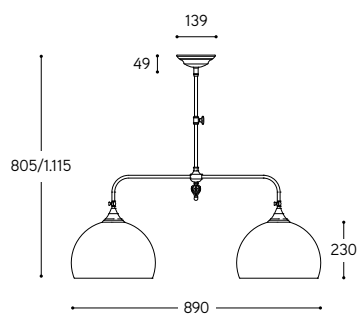

Art. 4600.3

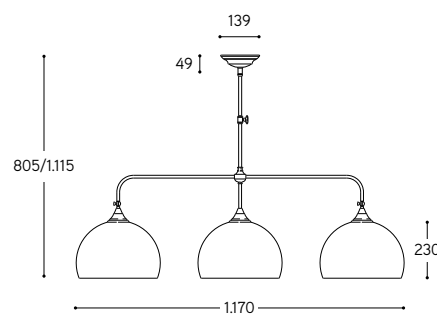

ARTICOLO ITEM	DESCRIZIONE DESCRIPTION	ATTACCO SOCKET	POTENZA POWER	PESO GR. WEIGHT GR.	VOL. IN M ³ VOL. IN M ³	PEZZI IMBALLO OUTER BOX	FASCIA PREZZO PRICE RANGE
4600.1	Sospensione 1 luce / 1 light pendant	E27	70W	4.580	0,07	1	B74
4600.2	Sospensione 2 luci / 2 lights pendant	E27	2x70W	10.000	0,20	1	B100
4600.3	Sospensione 3 luci / 3 lights pendant	E27	3x70W	12.440	0,38	1	B125

CE IP20  

LINEA
Tosca

Serie di sospensioni, regolabili in altezza al momento dell'installazione, con asta in ottone e riflettore in rame anticato, disponibili nelle versioni con riflettore bombato o "pagoda". Queste soluzioni, perfette in un ingresso o appese sopra ad un tavolo, donano all'ambiente una luce calda ed avvolgente.

Series of pendants, height-adjustable at installation time, with aged brass rod and aged copper shade, round-shaped or pagoda-shaped. These solutions, perfect hung above a table or in a hall, grace the room with warm, enveloping light.



Art. LAR.158.A







Art. LAR.160.A

Art. LAR.158.B

Art. LAR.159.B

Art. LAR.160.B

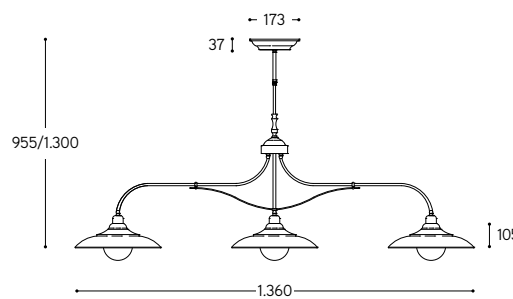
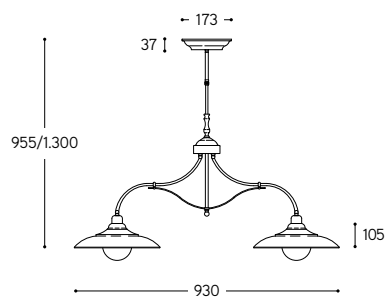
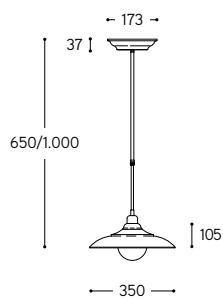

... A = Riflettore bombato
Rounded shade

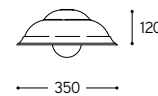

ARTICOLO ITEM	DESCRIZIONE DESCRIPTION	ATTACCO SOCKET	POTENZA POWER	PESO GR. WEIGHT GR.	VOL. IN M ³ VOL. IN M ³	PEZZI IMBALLO OUTER BOX	FASCIA PREZZO PRICE RANGE
LAR.158. ... (*)	Sospensione 1 luce / 1 light pendant	E27	70W	3.400	0,06	1	B59
LAR.159. ... (*)	Sospensione 2 luci / 2 lights pendant	E27	2x70W	7.000	0,17	1	B112
LAR.160. ... (*)	Sospensione 3 luci / 3 lights pendant	E27	3x70W	11.760	0,27	1	B130

CE IP20

(*) ... A = Riflettore bombato / Rounded shade
... B = Riflettore pagoda / Pagoda shade

LINEA
Mizar

Apparecchio a sospensione disponibile in ceramica bianca, filo colorato o ceramica "cotto". Queste soluzioni, perfette in un ingresso o appese sopra ad un tavolo, donano all'ambiente una luce calda ed avvolgente. Gli articoli possono essere corredati con accessori di nostra produzione, da ordinare a parte, presenti da pag. 144 a pag. 183 del catalogo.

Pendant available in white glazed ceramic, coloured line or "cotto" ceramic. These solutions, perfect hung above a table or in a hall, grace the room with warm, enveloping light. The fixture can be combined with the accessories visible from page 144 to page 183 of the catalogue and to be ordered separately.



Art. LAR.70.FR
Art. LAR.138.02
Art. LAR.131.00

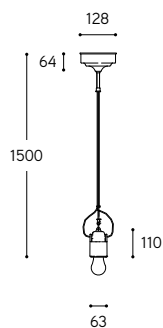

ARTICOLO ITEM	DESCRIZIONE DESCRIPTION	ATTACCO SOCKET	POTENZA POWER	PESO GR. WEIGHT GR.	VOL. IN M ³ VOL. IN M ³	PEZZI IMBALLO OUTER BOX	FASCIA PREZZO PRICE RANGE
LAR.70.00	Bianco / White						B33
LAR.70. ...	Filo colorato / Coloured line (*) Sospensione / Pendant	E27	42W	1.280	0,01	1	B34
LAR.70.C	Cotto / Cotto						B33

CE IP20

(*) ... FR = Filo rosso / Red line
 ... FM = Filo marrone / Brown line
 ... FA = Filo ramina / Green line
 ... FB = Filo blu / Blue line
 ... FO = Filo arancio / Orange line

I Fili colorati sono illustrati a pag. 184
 See Coloured lines on page 184

LINEA
Isola

Serie di sospensioni, applique e plafoniere disponibile in ceramica bianca, filo colorato o ceramica "cotto". Queste soluzioni, perfette in un ingresso o appese sopra ad un tavolo, donano all'ambiente una luce calda ed avvolgente. Gli articoli possono essere corredati con accessori di nostra produzione, da ordinare a parte, presenti da pag. 144 a pag. 183 del catalogo.

Series of pendants, wall and ceiling lamps available in white glazed ceramic, coloured line or "cotto" ceramic. These solutions, perfect hung above a table or in a hall, grace the room with warm, enveloping light. The fixture can be combined with the accessories visible from page 144 to page 183 of the catalogue and to be ordered separately.



Art. LAR.74.00
Art. LAR.138.02
Art. LAR.131.00



Art. LAR.74. ...

Art. LAR.94.FO
Art. LAR.138.02
Art. LAR.131.00

Art. LAR.98.FR
Art. LAR.134.B

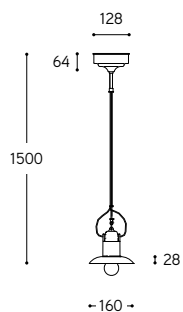

Art. LAR.94. ...

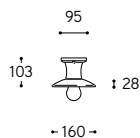

Art. LAR.98. ...



ARTICOLO ITEM	DESCRIZIONE DESCRIPTION	ATTACCO SOCKET	POTENZA POWER	PESO GR. WEIGHT GR.	VOL. IN M ³ VOL. IN M ³	PEZZI IMBALLO OUTER BOX	FASCIA PREZZO PRICE RANGE
Bianca / White							
LAR.74.00	Sospensione / Pendant	E27	42W	1.840	0,02	1	B37
LAR.94.00	Plafoniera / Ceiling lamp	E27	42W	800	0,01	1	B33
LAR.98.00	Applique / Wall lamp	E27	42W	820	0,01	1	B33
Fili colorati / Coloured lines (*)							
LAR.74. ...	Sospensione / Pendant	E27	42W	1.840	0,02	1	B39
LAR.94. ...	Plafoniera / Ceiling lamp	E27	42W	800	0,01	1	B34
LAR.98. ...	Applique / Wall lamp	E27	42W	820	0,01	1	B34
Cotto / Cotto							
LAR.74.C	Sospensione / Pendant	E27	42W	1.840	0,02	1	B37
LAR.94.C	Plafoniera / Ceiling lamp	E27	42W	800	0,01	1	B33
LAR.98.C	Applique / Wall lamp	E27	42W	820	0,01	1	B33

CE IP20

(*) ... FR = Filo rosso / Red line
 ... FM = Filo marrone / Brown line
 ... FA = Filo ramina / Green line
 ... FB = Filo blu / Blue line
 ... FO = Filo arancio / Orange line

I Fili colorati sono illustrati a pag. 184
 See Coloured lines on page 184

LINEA
Polare

Serie di sospensioni, applique e plafoniere. Il riflettore in rame invecchiato è disponibile nella versione conica o in quella rotonda. Queste soluzioni, perfette in un ingresso o appese sopra ad un tavolo, donano all'ambiente una luce calda ed avvolgente. Gli articoli possono essere corredati con accessori di nostra produzione, da ordinare a parte, presenti da pag. 144 a pag. 183 del catalogo.

Series of pendants, wall and ceiling lamps. The shade is in aged copper and available in conic or round versions. These solutions, perfect hung above a table or in a hall, grace the room with warm, enveloping light. The fixture can be combined with the accessories visible from page 144 to page 183 of the catalogue and to be ordered separately.



Art. LAR.95.03
Art. LAR.134.B

Art. LAR.71.01
Art. LAR.138.02
Art. LAR.131.00





Art. LAR.71.01

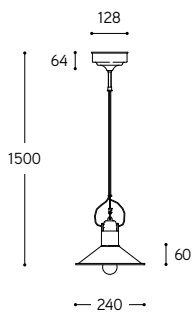

Art. LAR.71.03

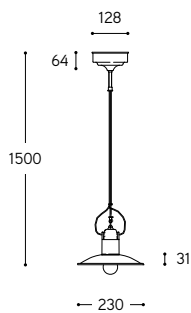

Art. LAR.71.04

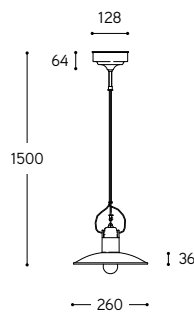

Art. LAR.91.01

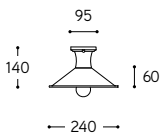

Art. LAR.91.03

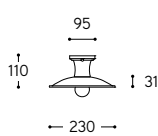

Art. LAR.91.04

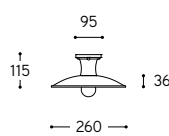

Art. LAR.95.01

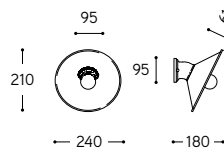

Art. LAR.95.03

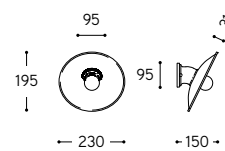

Art. LAR.95.04

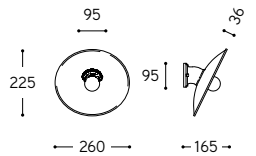

ARTICOLO ITEM	DESCRIZIONE DESCRIPTION	ATTACCO SOCKET	POTENZA POWER	PESO GR. WEIGHT GR.	VOL. IN M ³ VOL. IN M ³	PEZZI IMBALLO OUTER BOX	FASCIA PREZZO PRICE RANGE
------------------	----------------------------	-------------------	------------------	------------------------	--	----------------------------	------------------------------

Riflettore conico / Conic shade (*)

LAR.71.01	Sospensione / Pendant	E27	42W	2.120	0,03	1	B40
LAR.91.01	Plafoniera / Ceiling lamp	E27	42W	1.480	0,02	1	B37
LAR.95.01	Applique / Wall lamp	E27	42W	1.440	0,02	1	B37

Riflettore tondo piccolo / Little round shade (*)

LAR.71.03	Sospensione / Pendant	E27	42W	2.100	0,03	1	B40
LAR.91.03	Plafoniera / Ceiling lamp	E27	42W	1.440	0,02	1	B37
LAR.95.03	Applique / Wall lamp	E27	42W	1.360	0,02	1	B37

Riflettore tondo grande / Big round shade (*)

LAR.71.04	Sospensione / Pendant	E27	42W	2.210	0,03	1	B40
LAR.91.04	Plafoniera / Ceiling lamp	E27	42W	1.550	0,02	1	B37
LAR.95.04	Applique / Wall lamp	E27	42W	1.500	0,02	1	B37



(*) I Riflettori sono illustrati a pag. 186
See Shades on page 186

LINEA

Le Macine

Serie composta da sospensione e faretto ad incasso disponibili nelle versioni in ceramica bianca, decorata o cotto smaltato bianco. Queste soluzioni, perfette in un ingresso o appese sopra ad un tavolo, donano all'ambiente una luce calda ed avvolgente. L'apparecchio a sospensione può essere corredato con accessori di nostra produzione, da ordinare a parte, presenti da pag. 144 a pag. 183 del catalogo.

Series of pendant and recessed spotlight made of white glazed/ decorated or cotto-white glazed ceramic. These solutions, perfect hung above a table or in a hall, grace the room with warm, enveloping light. Pendant can be combined with the accessories visible from page 144 to page 183 of the catalogue and to be ordered separately.



Art. G11.38/A





Art. G10. ...

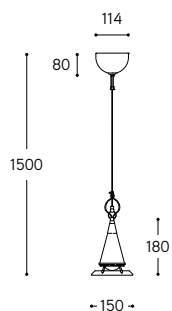

Art. G11. ...

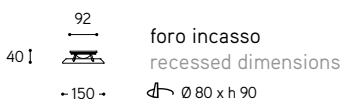

Il trasformatore è fornibile solo su richiesta.

Trasf. tor. 50VA 230V/12/V, G. 700,
Ø esterno 76 mm, Ø interno 27 mm, h 33 mm, omologato IMQ e VDE.

The transformer is available only on request.

Trasf. tor. 50VA 230V/12/V, G. 700
External Ø 76 mm, internal Ø 27 mm, h 33 mm, homologated IMQ e VDE.

ARTICOLO ITEM	DESCRIZIONE DESCRIPTION	ATTACCO SOCKET	POTENZA POWER	PESO GR. WEIGHT GR.	VOL. IN M ³ VOL. IN M ³	PEZZI IMBALLO OUTER BOX	FASCIA PREZZO PRICE RANGE
Bianca / White							
G10.00/A		E14	42W	1.770	0,06	1	B50
G10.00/B	Sospensione / Pendant	GX5,3	35W	1.770	0,06	1	B50
G10.00/C		GU10SP	50W	1.770	0,06	1	B50
G11.00/A		E14	42W	760	0,01	1	B40
G11.00/B	Faretto ad incasso / Recessed spotlight	GX5,3	35W	760	0,01	1	B40
G11.00/C		GU10SP	50W	760	0,01	1	B40
Decorata / Decorated (*)							
G10. .../A		E14	42W	1.770	0,06	1	B57
G10. .../B	Sospensione / Pendant	GX5,3	35W	1.770	0,06	1	B57
G10. .../C		GU10SP	50W	1.770	0,06	1	B57
G11. .../A		E14	42W	760	0,01	1	B45
G11. .../B	Faretto ad incasso / Recessed spotlight	GX5,3	35W	760	0,01	1	B45
G11. .../C		GU10SP	50W	760	0,01	1	B45
Cotto smaltato bianco / Cotto/White glazed							
G10.CB/A		E14	42W	1.770	0,06	1	B50
G10.CB/B	Sospensione / Pendant	GX5,3	35W	1.770	0,06	1	B50
G10.CB/C		GU10SP	50W	1.770	0,06	1	B50
G11.CB/A		E14	42W	760	0,01	1	B40
G11.CB/B	Faretto ad incasso / Recessed spotlight	GX5,3	35W	760	0,01	1	B40
G11.CB/C		GU10SP	50W	760	0,01	1	B40

CE IP20 per attacco tipo A e C / For lamp holder type A and C

IP20 per attacco tipo B / For lamp holder type B

(*) ... 07/V = Greca in verde / Green greek fret

... 08/B = Greca in blu / Blue greek fret

... 35 = Primavera blu / Blue spring

... 38 = Bordo verde / Green border

... 116 = Edera blu / Blue ivy

... 117 = Edera rossa / Red ivy

... 118 = Edera verde / Green ivy

... IB = Intreccio blu / Blue intertwine

I Decorati sono illustrati a pag. 184-185
See Decorations on page 184-185

LINEA

Le Ciotole

Serie composta da sospensione e faretto ad incasso in ceramica bianca e ottone precedentemente anticato. Queste soluzioni, perfette in un ingresso o appese sopra ad un tavolo, donano all'ambiente una luce calda ed avvolgente. L'apparecchio a sospensione può essere corredato con accessori di nostra produzione, da ordinare a parte, presenti da pag. 144 a pag. 183 del catalogo.

Series of pendant and recessed spotlight made of white glazed ceramic and aged brass. These solutions, perfect hung above a table or in a hall, grace the room with warm, enveloping light. Pendant can be combined with the accessories visible from page 144 to page 183 of the catalogue and to be ordered separately.



Art. G130/A



Art. G132/A

Art. G130

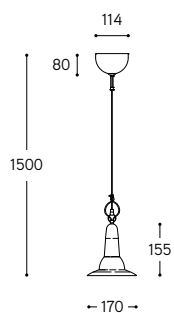

Art. G132

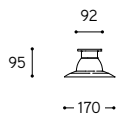

foro incasso
recessed dimensions
Ø 80 x h 90

Il trasformatore è fornibile solo su richiesta.

Trasf. tor. 50VA 230V/12/V, G. 700,
Ø esterno 76 mm, Ø interno 27 mm, h 33 mm, omologato IMQ e VDE.

The transformer is available only on request.

Trasf. tor. 50VA 230V/12/V, G. 700
External Ø 76 mm, internal Ø 27 mm, h 33 mm, homologated IMQ e VDE.

ARTICOLO ITEM	DESCRIZIONE DESCRIPTION	ATTACCO SOCKET	POTENZA POWER	PESO GR. WEIGHT GR.	VOL. IN M ³ VOL. IN M ³	PEZZI IMBALLO OUTER BOX	FASCIA PREZZO PRICE RANGE
G130/A		E14	42W	1.820	0,06	1	B55
G130/B	Sospensione / Pendant	GX5,3	35W	1.820	0,06	1	B55
G130/C		GU10SP	50W	1.820	0,06	1	B55
G132/A		E14	42W	1.000	0,01	1	B43
G132/B	Faretto ad incasso / Recessed spotlight	GX5,3	35W	1.000	0,01	1	B43
G132/C		GU10SP	50W	1.000	0,01	1	B43

CE IP20 per attacco tipo A e C / For lamp holder type A and C

IP20 per attacco tipo B / For lamp holder type B

LINEA

Le Ninfee

Serie composta da sospensione e faretto ad incasso disponibili nelle versioni in ceramica bianca o decorata. Queste soluzioni, perfette in un ingresso o appese sopra ad un tavolo, donano all'ambiente una luce calda ed avvolgente. L'apparecchio a sospensione può essere corredato con accessori di nostra produzione, da ordinare a parte, presenti da pag. 144 a pag. 183 del catalogo.

Series of pendant and recessed spotlight made of white glazed or decorated ceramic. These solutions, perfect hung above a table or in a hall, grace the room with warm, enveloping light. Pendant can be combined with the accessories visible from page 144 to page 183 of the catalogue and to be ordered separately.



Art. G330.00/A



Art. G331.DR/B

Art. G330. ...

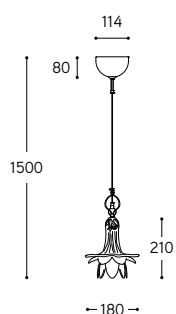

Art. G331. ...

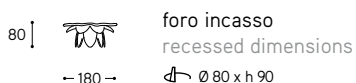

Il trasformatore è fornibile solo su richiesta.

Trasf. tor. 50VA 230V/12/V, G. 700, Ø esterno 76 mm, Ø interno 27 mm, h 33 mm, omologato IMQ e VDE.

The transformer is available only on request.

Trasf. tor. 50VA 230V/12/V, G. 700 External Ø 76 mm, internal Ø 27 mm, h 33 mm, homologated IMQ e VDE.

ARTICOLO ITEM	DESCRIZIONE DESCRIPTION	ATTACCO SOCKET	POTENZA POWER	PESO GR. WEIGHT GR.	VOL. IN M³ VOL. IN M³	PEZZI IMBALLO OUTER BOX	FASCIA PREZZO PRICE RANGE
Bianca / White							
G330.00/A		E14	42W	1.770	0,06	1	B54
G330.00/B	Sospensione / Pendant	GX5,3	35W	1.770	0,06	1	B54
G330.00/C		GU10SP	50W	1.770	0,06	1	B54
G331.00/A		E14	42W	760	0,01	1	B42
G331.00/B	Faretto ad incasso / Recessed spotlight	GX5,3	35W	760	0,01	1	B42
G331.00/C		GU10SP	50W	760	0,01	1	B42
Decorata / Decorated (*)							
G330. .../A		E14	42W	1.770	0,06	1	B59
G330. .../B	Sospensione / Pendant	GX5,3	35W	1.770	0,06	1	B59
G330. .../C		GU10SP	50W	1.770	0,06	1	B59
G331. .../A		E14	42W	760	0,01	1	B48
G331. .../B	Faretto ad incasso / Recessed spotlight	GX5,3	35W	760	0,01	1	B48
G331. .../C		GU10SP	50W	760	0,01	1	B48

CE IP20 per attacco tipo A e C / For lamp holder type A and C

IP20 per attacco tipo B / For lamp holder type B

(*) ... DR = Decoro rosa / Pink decoration
 ... DA = Decoro azzurro / Light blue decoration
 ... DG = Decoro giallo / Yellow decoration

LINEA I Narcisi

Faretto ad incasso disponibile nelle versioni in ceramica bianca o decorata. Queste soluzioni, perfette in un ingresso o appese sopra ad un tavolo, donano all'ambiente una luce calda ed avvolgente.

Recessed spotlight made of white glazed or decorated ceramic. These solutions, perfect hung above a table or in a hall, grace the room with warm, enveloping light.



Art. G311.D/A

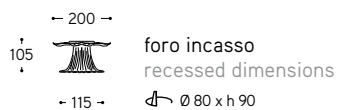

ARTICOLO ITEM	DESCRIZIONE DESCRIPTION	ATTACCO SOCKET	POTENZA POWER	PESO GR. WEIGHT GR.	VOL. IN M ³ VOL. IN M ³	PEZZI IMBALLO OUTER BOX	FASCIA PREZZO PRICE RANGE
Bianca / White							
G311.00/A		E14	42W	1.000	0,01	1	B42
G311.00/B	Faretto ad incasso / Recessed spotlight	GX5,3	35W	1.000	0,01	1	B42
G311.00/C		GU10SP	50W	1.000	0,01	1	B42
Decorata / Decorated							
G311.D/A		E14	42W	1.000	0,01	1	B48
G311.D/B	Faretto ad incasso / Recessed spotlight	GX5,3	35W	1.000	0,01	1	B48
G311.D/C		GU10SP	50W	1.000	0,01	1	B48

CE IP20 per attacco tipo A e C / For lamp holder type A and C

IP20 per attacco tipo B / For lamp holder type B

Il trasformatore è fornibile solo su richiesta.

Trasf. tor. 50VA 230V/12/V, G. 700,
Ø esterno 76 mm, Ø interno 27 mm, h 33 mm, omologato IMQ e VDE.

The transformer is available only on request.

Trasf. tor. 50VA 230V/12/V, G. 700
External Ø 76 mm, internal Ø 27 mm, h 33 mm, homologated IMQ e VDE.



RIVESTIMENTO / COATING

Ingobbio

Solitamente la parola “ingobbio” viene fatta derivare dal francese “engobe, engober” che significa “rivestire con uno strato di terra”. In effetti, con “ingobbio” s’intende, nell’industria ceramica, uno specifico rivestimento cremoso formato da un misto d’argille, diluite tra loro da particolari fondenti e corrette con coloranti al fine di ottenere le tonalità desiderate.

Questo speciale “rivestimento” viene steso sull’oggetto, in seconda cottura, a spruzzo, a bagno o a pennello.

Questo sistema di colorazione, anche per il suo basso costo, continuò a costituire nel corso dei secoli, pur nel variare della tipologia delle forme, la normale produzione per le classi meno abbienti.

Attualmente l’ingobbio è una tecnica artigianale utilizzata principalmente in campo artistico.

The word “engobe” is usually said to come the French “engobe, engober” meaning “to cover with a layer of earth”.

“Engobe” means, in the ceramic industry, a specific coating creamy made with a mixture of clays, diluted to each other by special melting and corrected with dyes in order to obtain the desired tone.

The special “coating” is applied on the object in second firing, by spraying, bath or brush.

This colouring system, even with the variations in product shape types, continued to form the standard procedure used in the following centuries by the less well-off classes, also due to its low cost.

Nowadays, “engobe” is an artisan technique mainly used in the artistic field.



APPLIQUE E PLAFONIERE WALL AND CEILING LAMPS

Saper illuminare un ambiente vuol dire dare luce, ma anche calore e colore alle attività, agli svaghi, al relax dell'ambiente circostante. Presentiamo in queste pagine una serie di applique, plafoniere e spot che sono anche elementi decorativi, classici e moderni allo stesso tempo.

To light a room means to give light, but also warmth and color to business, amusement and relaxation of environment.

We present in this paper a number of wall lamps, ceiling lights and spots that are also decorative, classic and modern at the same time.

LINEA
Lagazuoi

Apparecchio a parete in ottone anticato con placca copri base in gres ceramico ingobbiato. L'appliche è dotata di un braccio snodabile alle estremità che ne permette la regolazione desiderata. Questa soluzione, perfetta in un ingresso o appesa sopra ad un tavolo, dona all'ambiente una luce calda ed avvolgente.

Wall lamp with adjustable joint, made of aged brass with plate cover base in engobed ceramic. This solution, perfect hung above a table or in a hall, grace the room with warm, enveloping light.

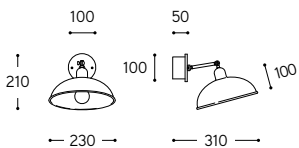

ARTICOLO ITEM	DESCRIZIONE DESCRIPTION	ATTACCO SOCKET	POTENZA POWER	PESO GR. WEIGHT GR.	VOL. IN M ³ VOL. IN M ³	PEZZI IMBALLO OUTER BOX	FASCIA PREZZO PRICE RANGE
10.320	Applique / Wall lamp	E27	42W	2.620	0,03	1	B103

CE IP20



LINEA 5 Torri

Apparecchio a parete con base in gres ceramico ingobbato e riflettore in ottone anticato. Questa soluzione, perfetta in un ingresso o appesa sopra ad un tavolo, dona all'ambiente una luce calda ed avvolgente.

Wall lamp, made of aged brass shade and base in engobed ceramic. This solution, perfect hung above a table or in a hall, grace the room with warm, enveloping light.

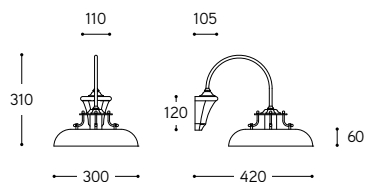

ARTICOLO ITEM	DESCRIZIONE DESCRIPTION	ATTACCO SOCKET	POTENZA POWER	PESO GR. WEIGHT GR.	VOL. IN M ³ VOL. IN M ³	PEZZI IMBALLO OUTER BOX	FASCIA PREZZO PRICE RANGE
10.720	Applique / Wall lamp	E27	70W	4.560	0,07	1	B107

CE IP20

LINEA
Tofane

Apparecchio a parete in ottone anticato con placca copri base in gres ceramico ingobbiato. Questa soluzione, perfetta in un ingresso o appesa sopra ad un tavolo, dona all'ambiente una luce calda ed avvolgente.

Wall lamp, made of aged brass with plate cover base in engobed ceramic. This solution, perfect hung above a table or in a hall, grace the room with warm, enveloping light.

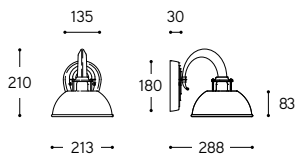

ARTICOLO ITEM	DESCRIZIONE DESCRIPTION	ATTACCO SOCKET	POTENZA POWER	PESO GR. WEIGHT GR.	VOL. IN M ³ VOL. IN M ³	PEZZI IMBALLO OUTER BOX	FASCIA PREZZO PRICE RANGE
10.521	Applique / Wall lamp	E27	70W	2.860	0,04	1	B94



LINEA

Alpe di Sennes

Apparecchio a parete con base in ceramica ingobbiata, braccio in ottone anticato e diffusore in vetro bianco latte lucido. Questa soluzione, perfetta in un ingresso o appesa sopra ad un tavolo, dona all'ambiente una luce calda ed avvolgente.

Wall lamp made of engobed ceramic base and shiny white-milk diffuser. This solution, perfect hung above a table or in a hall, grace the room with warm, enveloping light.

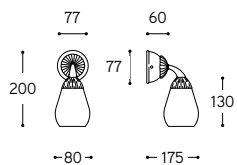

ARTICOLO ITEM	DESCRIZIONE DESCRIPTION	ATTACCO SOCKET	POTENZA POWER	PESO GR. WEIGHT GR.	VOL. IN M ³ VOL. IN M ³	PEZZI IMBALLO OUTER BOX	FASCIA PREZZO PRICE RANGE
10.120	Applique / Wall lamp	E14	42W	1.500	0,02	1	B76

CE IP20



LINEA
Moiazza

Apparecchio a parete con base e riflettore in gres ceramico ingobbato e con braccio e rosone copri base in ottone anticato. Questa soluzione, perfetta in un ingresso o appesa sopra ad un tavolo, dona all'ambiente una luce calda ed avvolgente.

Wall lamp, made of aged brass arm and engobed ceramic shade and base. This solution, perfect hung above a table or in a hall, grace the room with warm, enveloping light.

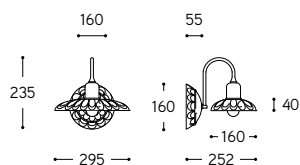

ARTICOLO ITEM	DESCRIZIONE DESCRIPTION	ATTACCO SOCKET	POTENZA POWER	PESO GR. WEIGHT GR.	VOL. IN M ³ VOL. IN M ³	PEZZI IMBALLO OUTER BOX	FASCIA PREZZO PRICE RANGE
11.620	Applique / Wall lamp	E27	42W	2.570	0,03	1	B98

CE IP20

LINEA

Capaeònga

Plafoniera con base in rame anticato, diffusore in vetro bianco-latte lucido ed anello in ceramica ingobbiata. Questa soluzione, perfetta in un ingresso o appesa sopra ad un tavolo, dona all'ambiente una luce calda ed avvolgente.

Ceiling lamp made of aged copper base, shiny white-milk diffuser and ceramic engobed ring. This solution, perfect hung above a table or in a hall, grace the room with warm, enveloping light.

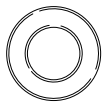

→ 185 ←

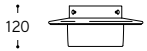

↑ 120 ↓

→ 325 ←

ARTICOLO ITEM	DESCRIZIONE DESCRIPTION	ATTACCO SOCKET	POTENZA POWER	PESO GR. WEIGHT GR.	VOL. IN M ³ VOL. IN M ³	PEZZI IMBALLO OUTER BOX	FASCIA PREZZO PRICE RANGE
41.22000	Plafoniera / Ceiling lamp	E27	42W *	3.840	0,07	1	B78
41.22000 fluor		G24d-2	18W	3.840	0,07	1	B82

CE IP40



LINEA
Bòsega

Plafoniera con base in rame anticato, diffusore in vetro bianco-latte lucido ed anello in ceramica ingobbiata. Questa soluzione, perfetta in un ingresso o appesa sopra ad un tavolo, dona all'ambiente una luce calda ed avvolgente.

Ceiling lamp made of aged copper base, shiny white-milk diffuser and ceramic engobed ring. This solution, perfect hung above a table or in a hall, grace the room with warm, enveloping light.

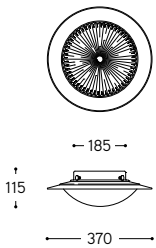

ARTICOLO ITEM	DESCRIZIONE DESCRIPTION	ATTACCO SOCKET	POTENZA POWER	PESO GR. WEIGHT GR.	VOL. IN M ³ VOL. IN M ³	PEZZI IMBALLO OUTER BOX	FASCIA PREZZO PRICE RANGE
41.21000	Plafoniera / Ceiling lamp	E27	42W *	4.500	0,08	1	B79
41.21000 fluor		G24d-2	18W	4.500	0,08	1	B83

CE IP40



LINEA
Allegro

Serie di faretti a parete disponibili nelle varianti in ceramica bianca, ingobbata ed ingobbio rosso. Per il suo design minimalista e le dimensioni ridotte si presta ad essere inserito in qualsiasi contesto d'arredo per interni.

Series of wall spots, available in white or engobed ceramic. The minimalist design and small size of the product allows it to be inserted in any context for indoor lighting.



Art. SI.A6.09

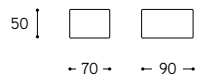

ARTICOLO ITEM	DESCRIZIONE DESCRIPTION	ATTACCO SOCKET	POTENZA POWER	PESO GR. WEIGHT GR.	VOL. IN M ³ VOL. IN M ³	PEZZI IMBALLO OUTER BOX	FASCIA PREZZO PRICE RANGE
SI.A6.00 Bianco / White							B37
SI.A6.08 Ingobbio invecchiato / Aged "Ingobbio"	Applique / Wall lamp	G9	28W	780	0,01	1	B37
SI.A6.09 Ingobbio rosso / Red "Ingobbio"							B37

CE IP20



LINEA Raggio

Apparecchio a parete disponibile in gres ceramico smaltato bianco a doppia emissione. Forme essenziali ed eleganti che diventano cuore dell'illuminazione di un interno. L'articolo è comprensivo di lampada.

Double emission wall lamp available in white glazed ceramic. Essential and elegant form that become the heart of an interior lighting. Bulb included.

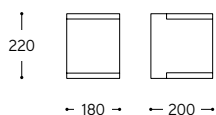

ARTICOLO ITEM	DESCRIZIONE DESCRIPTION		ATTACCO SOCKET	POTENZA POWER	PESO GR. WEIGHT GR.	VOL. IN M ³ VOL. IN M ³	PEZZI IMBALLO OUTER BOX	FASCIA PREZZO PRICE RANGE
RAGGIO BIANCO	Applique doppia emissione Double emission wall lamp	emissione superiore / upper emission	GX53	9W	6.240	0,04	1	B94
		emissione inferiore / lower emission	E27	23W PAR 38 megaman				

CE IP40



LINEA
Glamour

Serie di 3 apparecchi a parete in gres ceramico smaltato bianco con riflettore in metacrilato colore bianco/latte. Forme essenziali ed eleganti che diventano cuore dell'illuminazione di un interno.

Set of 3 white glazed ceramic wall lamp with white-milk shiny methacrylate reflector. Essential and elegant forms that become the heart of an interior lighting.



Art. GLA.1
Art. GLA.2
Art. GLA.3



Art. GLA.1

Art. GLA.1

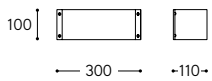

Art. GLA.2

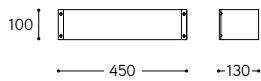

Art. GLA.3

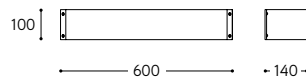

ARTICOLO ITEM	DESCRIZIONE DESCRIPTION	ATTACCO SOCKET	POTENZA POWER	PESO GR. WEIGHT GR.	VOL. IN M ³ VOL. IN M ³	PEZZI IMBALLO OUTER BOX	FASCIA PREZZO PRICE RANGE
GLA.1	Applique piccolo / Little wall lamp	G24d-2	18W	2.220	0,02	1	B64
GLA.2	Applique medio / Medium wall lamp	G24d-3	26W	3.780	0,06	1	B81
GLA.3	Applique grande / Big wall lamp	2G11 TCL	36W	4.520	0,06	1	B91

CE IP40

LINEA
Luna

Apparecchio a parete disponibile nelle versioni in ceramica bianca, filo colorato, ceramica "cotto", o "cotto" smaltato bianco. Questa soluzione, perfetta in un ingresso o appesa sopra ad un tavolo, dona all'ambiente una luce calda ed avvolgente.

Wall lamp available in white glazed ceramic, coloured line, "cotto" ceramic or cotto/white glazed ceramic. This solution, perfect hung above a table or in a hall, grace the room with warm, enveloping light.

Art. G05.FB/01



Art. G05.CB/01



ARTICOLO ITEM	DESCRIZIONE DESCRIPTION	ATTACCO SOCKET	POTENZA POWER	PESO GR. WEIGHT GR.	VOL. IN M ³ VOL. IN M ³	PEZZI IMBALLO OUTER BOX	FASCIA PREZZO PRICE RANGE
Bianca / White							
G05.00/01	Applique / Wall lamp	E27	70W *	1.500	0,02	1	B39
G05.00/02		R7s	120W	1.500	0,02	1	B42
Fili colorati / Coloured lines (*)							
G05. ... /01	Applique / Wall lamp	E27	70W *	1.500	0,02	1	B42
G05. ... /02		R7s	120W	1.500	0,02	1	B44
Cotto / Cotto							
G05.C/01	Applique / Wall lamp	E27	70W *	1.500	0,02	1	B39
G05.C/02		R7s	120W	1.500	0,02	1	B42
Cotto smaltato bianco / Cotto/White glazed							
G05.CB/01	Applique / Wall lamp	E27	70W *	1.500	0,02	1	B42
G05.CB/02		R7s	120W	1.500	0,02	1	B44

CE IP20

(*) ... **FR** = Filo rosso / Red line
 ... **FM** = Filo marrone / Brown line
 ... **FA** = Filo ramina / Green line
 ... **FB** = Filo blu / Blue line
 ... **FO** = Filo arancio / Orange line

I Fili colorati sono illustrati a pag. 184
 See Coloured lines on page 184



Scultura: "BEPIN" dell'artista Aldo Clerici

Art. E30/01



Art. E45/01

LINEA
Elisse

Apparecchio a parete in gesso bianco, per illuminazione da interno.
È disponibile in due misure.

Wall lamp in white gypsum, for indoor lighting.
It's available in two dimensions.

Art. E30

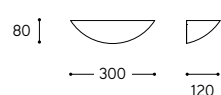

Art. E45

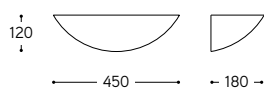

ARTICOLO ITEM	DESCRIZIONE DESCRIPTION	ATTACCO SOCKET	POTENZA POWER	PESO GR. WEIGHT GR.	VOL. IN M ³ VOL. IN M ³	PEZZI IMBALLO OUTER BOX	FASCIA PREZZO PRICE RANGE
E30/01	Applique gesso / Gypsum wall lamp	E27	42W *	1.500	0,02	1	B37
E30/02		R7s	80W	1.500	0,02	1	B38
E45/01	Applique gesso / Gypsum wall lamp	E27	70W *	2.810	0,06	1	B43
E45/02		R7s	120W	2.810	0,06	1	B45

CE IP20 *



LINEA
Preludio

Serie di applique con braccio in ferro verniciato a polveri e successivamente anticato, riflettore in ceramica bianca, "cotto" o filo colorato. Queste soluzioni, perfetta in un ingresso o appesa sopra ad un tavolo, dona all'ambiente una luce calda ed avvolgente.

Series of sconces with arm made of powder coated iron subsequently aged and shade in white, "cotto" or coloured line ceramic. These solutions, perfect hung above a table or in a hall, grace the room with warm, enveloping light.



Art. DO.A1.FB



Art. DO.A2.FR

Art. DO.A1. ...

Art. DO.A2. ...

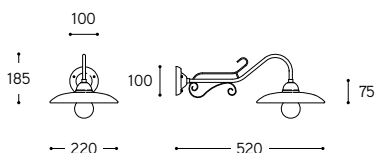
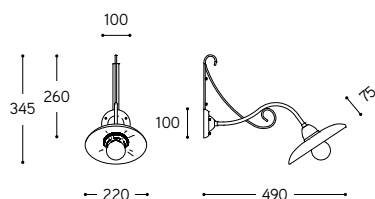

ARTICOLO ITEM	DESCRIZIONE DESCRIPTION	ATTACCO SOCKET	POTENZA POWER	PESO GR. WEIGHT GR.	VOL. IN M ³ VOL. IN M ³	PEZZI IMBALLO OUTER BOX	FASCIA PREZZO PRICE RANGE
Bianca / White							
DO.A1.00	Applique / Wall lamp	E27	70W	2.040	0,04	1	B50
DO.A2.00	Applique / Wall lamp	E27	70W	1.980	0,04	1	B50
Fili colorati / Coloured lines (*)							
DO.A1. ...	Applique / Wall lamp	E27	70W	2.040	0,04	1	B55
DO.A2. ...	Applique / Wall lamp	E27	70W	1.980	0,04	1	B55
Cotto / Cotto							
DO.A1.C	Applique / Wall lamp	E27	70W	2.040	0,04	1	B50
DO.A2.C	Applique / Wall lamp	E27	70W	1.980	0,04	1	B50

CE IP20

(*) ... FR = Filo rosso / Red line
 ... FM = Filo marrone / Brown line
 ... FA = Filo ramina / Green line
 ... FB = Filo blu / Blue line
 ... FO = Filo arancio / Orange line

I Fili colorati sono illustrati a pag. 184
 See Coloured lines on page 184

Art. LAR.93.C/22
Art. LAR.134.B

LINEA
Cappe

Plafoniera e applique disponibile nelle versioni in ceramica bianca, filo colorato o ceramica "cotto". Queste soluzioni, perfette in un ingresso o sopra ad un tavolo, donano all'ambiente una luce calda ed avvolgente. Gli articoli possono essere corredati con accessori di nostra produzione, da ordinare a parte, presenti da pag. 144 a pag. 183 del catalogo.

Ceiling and wall lamp available in white glazed ceramic, coloured line or decorated ceramic or "cotto" ceramic. These solutions, perfect above a table or in a hall, grace the room with warm, enveloping light. The fixture can be combined with the accessories visible from page 144 to page 183 of the catalogue and to be ordered separately.



Art. LAR.97.FM/22
Art. LAR.134.B





Art. LAR.93. .../22

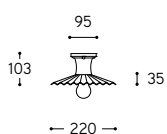

Art. LAR.93. .../26

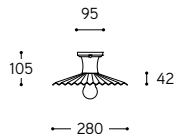

Art. LAR.97. .../22

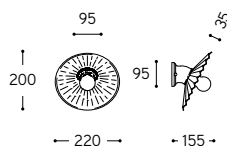

Art. LAR.97. .../26

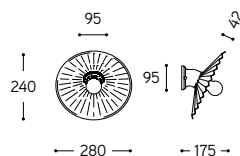

ARTICOLO ITEM	DESCRIZIONE DESCRIPTION	ATTACCO SOCKET	POTENZA POWER	PESO GR. WEIGHT GR.	VOL. IN M ³ VOL. IN M ³	PEZZI IMBALLO OUTER BOX	FASCIA PREZZO PRICE RANGE
Bianca / White							
LAR.93.00/22	Plafoniera / Ceiling lamp	E27	42W	1.280	0,02	1	B37
LAR.93.00/26	Plafoniera / Ceiling lamp	E27	42W	1.300	0,03	1	B39
LAR.97.00/22	Applique / Wall lamp	E27	42W	1.280	0,02	1	B37
LAR.97.00/26	Applique / Wall lamp	E27	42W	1.300	0,03	1	B39
Fili colorati / Coloured lines (*)							
LAR.93. .../22	Plafoniera / Ceiling lamp	E27	42W	1.280	0,02	1	B39
LAR.93. .../26	Plafoniera / Ceiling lamp	E27	42W	1.300	0,03	1	B42
LAR.97. .../22	Applique / Wall lamp	E27	42W	1.280	0,02	1	B39
LAR.97. .../26	Applique / Wall lamp	E27	42W	1.300	0,03	1	B42
Cotto / Cotto							
LAR.93.C/22	Plafoniera / Ceiling lamp	E27	42W	1.280	0,02	1	B37
LAR.93.C/26	Plafoniera / Ceiling lamp	E27	42W	1.300	0,03	1	B39
LAR.97.C/22	Applique / Wall lamp	E27	42W	1.280	0,02	1	B37
LAR.97.C/26	Applique / Wall lamp	E27	42W	1.300	0,03	1	B39

CE □ IP20  

(*) ... **FR** = Filo rosso / Red line
 ... **FM** = Filo marrone / Brown line
 ... **FA** = Filo ramina / Green line
 ... **FB** = Filo blu / Blue line
 ... **FO** = Filo arancio / Orange line

I Fili colorati sono illustrati a pag. 184
 See Coloured lines on page 184

LINEA

Andromeda

Apparecchio a soffitto disponibile nelle versioni in ceramica bianca, filo colorato o ceramica "cotto". L'articolo può essere corredato con accessori di nostra produzione, da ordinare a parte, presenti da pag. 144 a pag. 183 del catalogo.

Ceiling fixture available in white glazed ceramic, coloured line or "cotto" ceramic. Fixtures can be combined with the accessories visible from page 144 to page 183 of the catalogue and to be ordered separately.



Art. LAR.80.FB
Art. LAR.138.02
Art. LAR.131.00



- 95 -

ARTICOLO ITEM	DESCRIZIONE DESCRIPTION	ATTACCO SOCKET	POTENZA POWER	PESO GR. WEIGHT GR.	VOL. IN M ³ VOL. IN M ³	PEZZI IMBALLO OUTER BOX	FASCIA PREZZO PRICE RANGE
LAR.80.00 Bianco / White							B30
LAR.80. ... Filo colorato / Coloured line (*)	Spot a soffitto / Ceiling spot	E27	42W	680	0,01	1	B32
LAR.80.C Cotto / Cotto							B30

CE IP20

(*) ... FR = Filo rosso / Red line
... FM = Filo marrone / Brown line
... FA = Filo ramina / Green line
... FB = Filo blu / Blue line
... FO = Filo arancio / Orange line

I Fili colorati sono illustrati a pag. 184
See Coloured lines on page 184



LINEA
Mirfak

Apparecchio a parete disponibile nelle versioni in ceramica bianca, filo colorato o ceramica "cotto". L'articolo può essere corredato con accessori di nostra produzione, da ordinare a parte, presenti da pag. 144 a pag. 183 del catalogo.

Wall fixture available in white glazed ceramic, coloured line or "cotto" ceramic. Fixtures can be combined with the accessories visible from page 144 to page 183 of the catalogue and to be ordered separately.



Art. LAR.85.C
Art. LAR.134.B



-- 130 --

ARTICOLO ITEM	DESCRIZIONE DESCRIPTION	ATTACCO SOCKET	POTENZA POWER	PESO GR. WEIGHT GR.	VOL. IN M ³ VOL. IN M ³	PEZZI IMBALLO OUTER BOX	FASCIA PREZZO PRICE RANGE
LAR.85.00 Bianco / White							B30
LAR.85. ... Filo colorato / Coloured line (*)	Spot a parete a 45° / Wall spot 45°	E27	42W	680	0,01	1	B32
LAR.85.C Cotto / Cotto							B30

CE IP20

- (*) ... FR = Filo rosso / Red line
- ... FM = Filo marrone / Brown line
- ... FA = Filo ramina / Green line
- ... FB = Filo blu / Blue line
- ... FO = Filo arancio / Orange line

I Fili colorati sono illustrati a pag. 184
See Coloured lines on page 184

LINEA
Quaranta

Apparecchio a parete in ceramica bianca e diffusore bianco latte lucido.

Wall fixture available in white glazed ceramic and shiny white-milk diffuser.

Art. 40/B



Art. 40/D

Art. 40/B

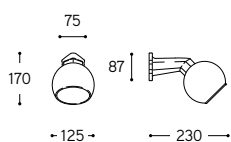

Art. 40/D

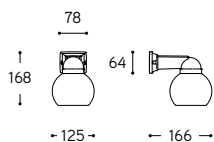

ARTICOLO ITEM	DESCRIZIONE DESCRIPTION	ATTACCO SOCKET	POTENZA POWER	PESO GR. WEIGHT GR.	VOL. IN M ³ VOL. IN M ³	PEZZI IMBALLO OUTER BOX	FASCIA PREZZO PRICE RANGE
40/B	Applique / Wall lamp	E27	42W	960	0,01	1	B34
40/D	Applique / Wall lamp	E27	42W	960	0,01	1	B34



LINEA
Orologi

Orologio a parete in ceramica disponibile anche nella versione decorata. È un elemento decorativo che si abbina alle linee di apparecchi di illuminazione di nostra produzione.

Ceramic wall clock available in white and decorated ceramic. It's a decorative element that may be combined with all our series of lighting equipment.



Art. TEM.412



Art. TEM.117

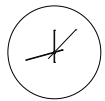

— 330 —

ARTICOLO ITEM	DESCRIZIONE DESCRIPTION	PESO GR. WEIGHT GR.	VOL. IN M ³ VOL. IN M ³	PEZZI IMBALLO OUTER BOX	FASCIA PREZZO PRICE RANGE
TEM.00 Bianco / White	Orologio / Clock	1.100	0,02	1	B33
TEM. ... Decorato / Decorated (*)					B40

CE IP20

(*) ... 01 = Delft blu / Delft
 ... 05 = Vite / Grapevine
 ... 06 = Anemone / Anemone
 ... 07/V = Greca in verde / Green greek fret
 ... 08/B = Greca in blu / Blue greek fret
 ... 35 = Primavera blu / Blue spring
 ... 38 = Bordo verde / Green border

... 116 = Edera blu / Blue ivy
 ... 117 = Edera rossa / Red ivy
 ... 118 = Edera verde / Green ivy
 ... 313 = Foglie / Leaf
 ... 412 = Tulipani / Tulip
 ... IB = Intreccio blu / Blue intertwine

I Decorati sono illustrati a pag. 184-185
 See Decorations on page 184-185

LED INSIDE

Faretti da soffitto e/o parete realizzati in elegante ceramica smaltata, disponibili in diverse forme e colorazioni.

Uno splendido connubio tra design e tecnologia per una serie di prodotti che danno nuovo ritmo all'illuminazione da interno.

Elegant glazed ceramic ceiling and/or wall spotlights available in different shapes and colours. A wonderful alliance of technology and design for a series of products that give a new rhythm to interior lighting.

Art. B1.CT



LINEA
Bachata

B1

Faretto a parete o segnapasso, in ceramica, a base quadrata, ad illuminazione indiretta, **comprensivo di scatola da incasso. Alimentatore incluso.** I faretti sono disponibili in una gamma di 8 colori.

Ceramic wall spotlight or path light with square base for indirect lighting, **back box included. Transformer included.** Spotlights are available in a range of 8 colours.



Art. B1.BL

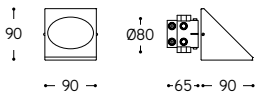

ARTICOLO ITEM	DESCRIZIONE DESCRIPTION	ALIMENTAZIONE E MODULO LED POWER AND LED MODULE	COLORE LED LED COLOUR	PESO GR. WEIGHT GR.	VOL. IN M ³ VOL. IN M ³	PEZZI IMBALLO OUTER BOX	FASCIA PREZZO PRICE RANGE
B1. ... (*)	Faretto ad incasso o segnapasso Recessed spotlight or path light	350mA (1,2W)	B11 - 3000K Bianco caldo Warm white	1.450	0,01	1	B36

CE □ IP20

(*) ... **BL** = Bianco lucido / Glossy white
 ... **BO** = Bianco opaco / Matte white
 ... **NL** = Nero lucido / Glossy black
 ... **NO** = Nero opaco / Matte black

... **MR** = Metal rame / Copper metal
 ... **R** = Rosso opaco / Matte red
 ... **VL** = Verde lucido / Glossy green
 ... **CT** = Craquellé Turquoise / Turquoise craquele

Le Finiture sono illustrate a pag. 187
 See Finishings on page 187



LINEA

Bachata

B2

Faretto a parete o segnapasso, in ceramica, di forma conica su base triangolare, ad illuminazione indiretta, **comprensivo di scatola da incasso. Alimentatore incluso.** I faretti sono disponibili in una gamma di 8 colori.

Ceramic cone shaped wall spotlight or path light with triangular base for indirect lighting, **back box included. Transformer included.** Spotlights are available in a range of 8 colours.



Art. B2.BO

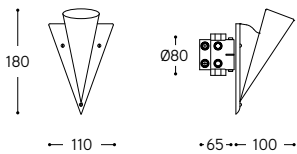

ARTICOLO ITEM	DESCRIZIONE DESCRIPTION	ALIMENTAZIONE E MODULO LED POWER AND LED MODULE	COLORE LED LED COLOUR	PESO GR. WEIGHT GR.	VOL. IN M ³ VOL. IN M ³	PEZZI IMBALLO OUTER BOX	FASCIA PREZZO PRICE RANGE
B2. ... (*)	Faretto ad incasso o segnapasso Recessed spotlight or path light	350mA (1,2W)	BI1 - 3000K Bianco caldo Warm white	300	0,01	1	B39

CE □ IP20

(*) ... **BL** = Bianco lucido / Glossy white
 ... **BO** = Bianco opaco / Matte white
 ... **NL** = Nero lucido / Glossy black
 ... **NO** = Nero opaco / Matte black

... **MR** = Metal rame / Copper metal
 ... **R** = Rosso opaco / Matte red
 ... **VL** = Verde lucido / Glossy green
 ... **CT** = Craquellé Turquoise / Turquoise craquele

Le Finiture sono illustrate a pag. 187
 See Finishings on page 187



LINEA
Bachata

B3

Faretto a parete, in ceramica, di forma rettangolare, arricchito da 3 staffe in ottone satinato o con finitura argento. **Alimentatore incluso.** I faretti sono disponibili in una gamma di 8 colori.

Ceramic rectangular wall spotlight embellished by 3 satin brackets in brass or silver finish. **Transformer included.** Spotlights are available in a range of 8 colours.



Art. B3S.MR

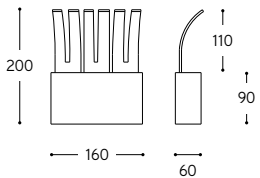

ARTICOLO ITEM	DESCRIZIONE DESCRIPTION	ALIMENTAZIONE E MODULO LED POWER AND LED MODULE	COLORE LED LED COLOUR	PESO GR. WEIGHT GR.	VOL. IN M ³ VOL. IN M ³	PEZZI IMBALLO OUTER BOX	FASCIA PREZZO PRICE RANGE
B3S. ... (*)	Faretto a parete staffe ottone satinato Wall spotlight with satin finish brass brackets	350mA (3x1,2W)	BI1 - 3000K Bianco caldo Warm white	1.540	0,02	1	B57
B3A. ... (*)	Faretto a parete staffe argento Wall spotlight with silver finish brackets		B57				

CE □ IP20

(*) ... **BL** = Bianco lucido / Glossy white
 ... **BO** = Bianco opaco / Matte white
 ... **NL** = Nero lucido / Glossy black
 ... **NO** = Nero opaco / Matte black

... **MR** = Metal rame / Copper metal
 ... **R** = Rosso opaco / Matte red
 ... **VL** = Verde lucido / Glossy green
 ... **CT** = Craquellé Turquoise / Turquoise craquele

Le Finiture sono illustrate a pag. 187
 See Finishings on page 187



Art. S1.R



LINEA
Samba

S1 - S2

Faretto ad incasso, in ceramica, a parete o parete/segnapasso, di forma rettangolare, ad illuminazione diretta (S1) o indiretta (S2), **comprensivo di scatola da incasso.**

Alimentatore incluso.

I faretti sono disponibili in una gamma di 8 colori.

Rectangular ceramic wall recessed spotlight or wall/path light for direct (S1) or indirect (S2) lighting **with back box. Transformer included.** Spotlights are available in a range of 8 colours.



Art. S2.VL

Art. S1. ...

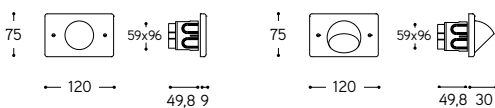

Art. S2.VL

ARTICOLO ITEM	DESCRIZIONE DESCRIPTION	ALIMENTAZIONE E MODULO LED POWER AND LED MODULE	COLORE LED LED COLOUR	PESO GR. WEIGHT GR.	VOL. IN M ³ VOL. IN M ³	PEZZI IMBALLO OUTER BOX	FASCIA PREZZO PRICE RANGE
S1. ... (*)	Faretto ad incasso rettangolare ad illuminazione diretta Rectangular recessed spotlight for direct lighting	350mA (1,2W)	BI1 - 3000K Bianco caldo Warm white	630	0,01	1	B32
S2. ... (*)	Faretto ad incasso rettangolare ad illuminazione indiretta Rectangular recessed spotlight for indirect lighting	350mA (1,2W)	BI1 - 3000K Bianco caldo Warm white	630	0,01	1	B33

CE IP20

(*) ... **BL** = Bianco lucido / Glossy white
 ... **BO** = Bianco opaco / Matte white
 ... **NL** = Nero lucido / Glossy black
 ... **NO** = Nero opaco / Matte black

... **MR** = Metal rame / Copper metal
 ... **R** = Rosso opaco / Matte red
 ... **VL** = Verde lucido / Glossy green
 ... **CT** = Craquellé Turquoise / Turquoise craquèle

Le Finiture sono illustrate a pag. 187
 See Finishings on page 187



Art. S3.NL



Art. S4.CT

LINEA
Samba
S3 - S4

Faretto ad incasso, in ceramica, a parete o parete/segnapasso, di forma quadrata, ad illuminazione diretta (S3) o indiretta (S4), **comprensivo di scatola da incasso.**

Alimentatore incluso.

I faretto sono disponibili in una gamma di 8 colori.

Square ceramic wall recessed spotlight or wall/path light for direct (S3) or indirect (S4) lighting **with back box. Transformer included.**

Spotlights are available in a range of 8 colours.

Art. S3. ...

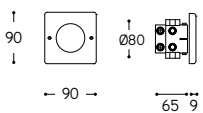

Art. S4. ...

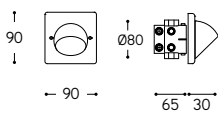

ARTICOLO ITEM	DESCRIZIONE DESCRIPTION	ALIMENTAZIONE E MODULO LED POWER AND LED MODULE	COLORE LED LED COLOUR	PESO GR. WEIGHT GR.	VOL. IN M ³ VOL. IN M ³	PEZZI IMBALLO OUTER BOX	FASCIA PREZZO PRICE RANGE
S3. ... (*)	Faretto ad incasso quadrato ad illuminazione diretta Square recessed spotlight for direct lighting	350mA (1,2W)	B11 - 3000K Bianco caldo Warm white	570	0,01	1	B31
S4. ... (*)	Faretto ad incasso quadrato ad illuminazione indiretta Square recessed spotlight for indirect lighting	350mA (1,2W)	B11 - 3000K Bianco caldo Warm white	570	0,01	1	B32

CE IP20

(*) ... **BL** = Bianco lucido / Glossy white
 ... **BO** = Bianco opaco / Matte white
 ... **NL** = Nero lucido / Glossy black
 ... **NO** = Nero opaco / Matte black

... **MR** = Metal rame / Copper metal
 ... **R** = Rosso opaco / Matte red
 ... **VL** = Verde lucido / Glossy green
 ... **CT** = Craquellé Turquoise / Turquoise craquèle

Le Finiture sono illustrate a pag. 187
 See Finishings on page 187



Art. M1.BL



Art. M2.NO

LINEA
Milonga

M1 - M2

Faretto ad incasso, in ceramica, a parete o parete/segnapasso, di forma rotonda, ad illuminazione diretta (M1) o indiretta (M2), **comprensivo di scatola da incasso.**

Alimentatore incluso.

I faretti sono disponibili in una gamma di 8 colori.

Round ceramic wall recessed spotlight or wall/path light for direct (M1) or indirect (M2) lighting **with back box. Transformer included.**

Spotlights are available in a range of 8 colours.

Art. M1. ...

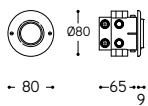

Art. M2. ...

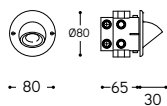

ARTICOLO ITEM	DESCRIZIONE DESCRIPTION	ALIMENTAZIONE E MODULO LED POWER AND LED MODULE	COLORE LED LED COLOUR	PESO GR. WEIGHT GR.	VOL. IN M ³ VOL. IN M ³	PEZZI IMBALLO OUTER BOX	FASCIA PREZZO PRICE RANGE
M1. ... (*)	Faretto ad incasso rotondo ad illuminazione diretta Round recessed spotlight for direct lighting	350mA (1,2W)	BI1 - 3000K Bianco caldo Warm white	510	0,01	1	B29
M2. ... (*)	Faretto ad incasso rotondo ad illuminazione indiretta Round recessed spotlight for indirect lighting	350mA (1,2W)	BI1 - 3000K Bianco caldo Warm white	510	0,01	1	B31

CE □ IP20

(*) ... **BL** = Bianco lucido / Glossy white
 ... **BO** = Bianco opaco / Matte white
 ... **NL** = Nero lucido / Glossy black
 ... **NO** = Nero opaco / Matte black

... **MR** = Metal rame / Copper metal
 ... **R** = Rosso opaco / Matte red
 ... **VL** = Verde lucido / Glossy green
 ... **CT** = Craquellé Turquoise / Turquoise craquèle

Le Finiture sono illustrate a pag. 187
 See Finishings on page 187



LINEA
Tango

T1 - T2

Linea di faretti da incasso in ceramica. Le strutture, comprensive di scatola da incasso, possono comporsi di uno, due o tre corpi luce ad illuminazione diretta (T1) o indiretta (T2), posizionati su cornice tonda ad 1, 2 o 3 uscite, da ordinare a parte. **Alimentatore incluso.**

Line of recessed ceramic spotlights. The structures, including the back box, can fit one, two or three spotlights for direct or indirect lighting. The lights can be fitted with round frame suitable for 1, 2 or 3 lights, to be ordered separately. **Transformer included.**





Come ordinare un prodotto / Example of order:

Scegliere il tipo di cornice:

- 1 foro (R1)

- 2 fori (R2)

- 3 fori (R3)

disponibile in 4 varianti colore
(vedi **(*)** pag. 155)

Choose the frame:

- 1 hole (R1)

- 2 holes (R2)

- 3 holes (R3)

available in 4 colours

(see **(*)** on page 155)**R1****R2****R3**

Scegliere il tipo di corpo luce:

- ad illuminazione diretta (T1)

- ad illuminazione indiretta (T2)

disponibile in 8 varianti colore
(vedi **(**)** pag. 155)

Choose the lighting device:

- direct lighting (T1)

- indirect lighting (T2)

Available in 8 colours

(see **(**)** on page 155)**T1**Illuminazione diretta
Direct lighting**T2**Illuminazione indiretta
Indirect lightingIndicare il numero di
corpi luce:

- n° 1 (per cornice R1)

- n° 2 (per cornice R2)

- n° 3 (per cornice R3)

Mark lighting devices
number:

- n° 1 (for frame R1)

- n° 2 (for frame R2)

- n° 3 (for frame R3)

Esempio di composizione / Example of composition:

**x2**n° 1 **R2.BL**n° 2 **T1.VL**n° 1 **R2.BL**n° 2 **T1.VL**Composizione codice finale
Final code composition

Alcuni esempi di composizione / Some examples of composition:

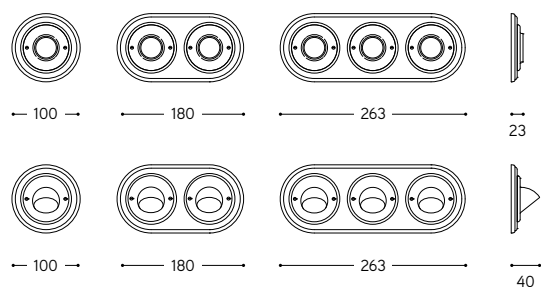
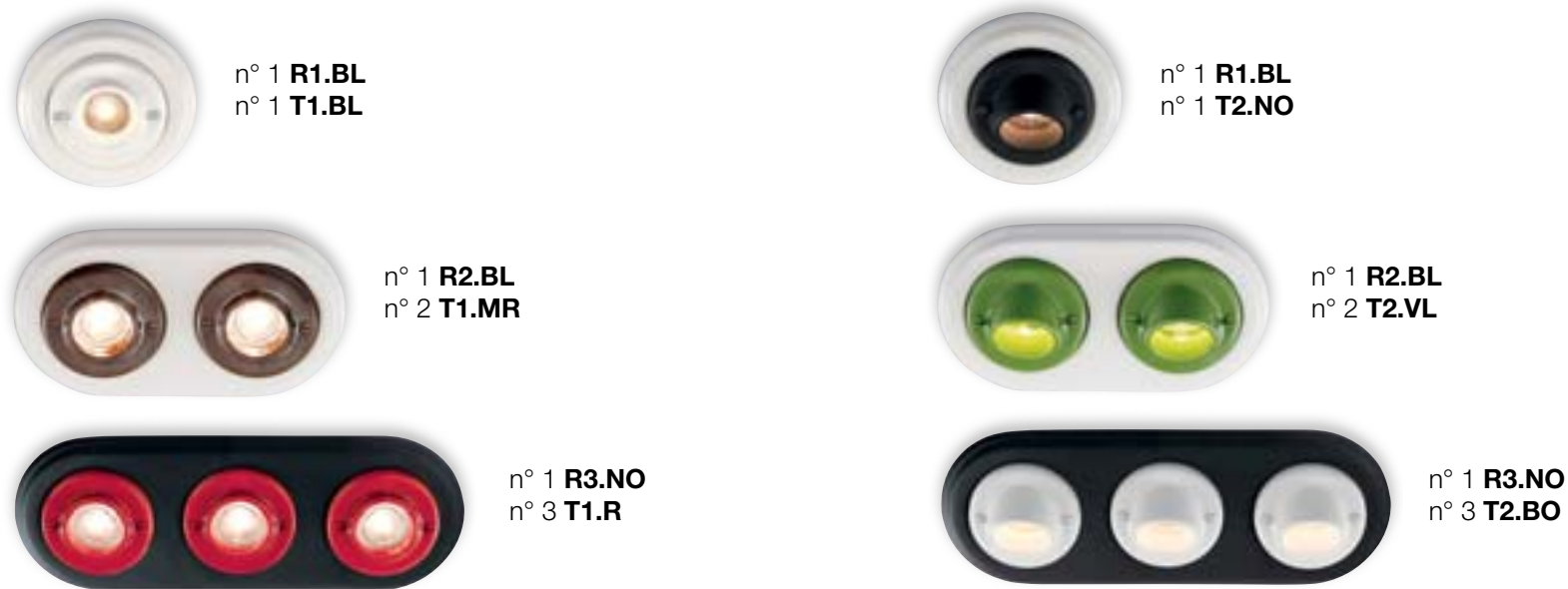

ARTICOLO ITEM	DESCRIZIONE DESCRIPTION	ALIMENTAZIONE E MODULO LED POWER AND LED MODULE	COLORE LED LED COLOUR	PESO GR. WEIGHT GR.	VOL. IN M³ VOL. IN M³	PEZZI IMBALLO OUTER BOX	FASCIA PREZZO PRICE RANGE
---------------	-------------------------	---	-----------------------	---------------------	-----------------------	-------------------------	---------------------------

Cornici (da ordinare a parte) / Ceramic frames (to be ordered separately)

R1. ... (*)	Cornice rotonda singola / Single light round frame			570	0,01	1	B12
R2. ... (*)	Cornice rotonda doppia / Double lights round frame			670	0,01	1	B19
R3. ... (*)	Cornice rotonda tripla / Triple lights round frame			770	0,01	1	B23

Corpo luce / Spotlight

T1. ... (**)	Corpo luce ad illuminazione diretta Spotlight for direct lighting	350mA (1,2W)	BI1 - 3000K Bianco caldo Warm white			1	B26
T2. ... (**)	Corpo luce ad illuminazione indiretta Spotlight for indirect lighting	350mA (1,2W)	BI1 - 3000K Bianco caldo Warm white			1	B29



(**) Finiture corpo luce disponibili / Available spotlight finishes:

(*) Finiture cornici disponibili / Available frames finishes:

- ... BL = Bianco lucido / Glossy white
- ... BO = Bianco opaco / Matte white
- ... NL = Nero lucido / Glossy black
- ... NO = Nero opaco / Matte black

- ... BL = Bianco lucido / Glossy white
- ... BO = Bianco opaco / Matte white
- ... NL = Nero lucido / Glossy black
- ... NO = Nero opaco / Matte black
- ... MR = Metal rame / Copper metal
- ... R = Rosso opaco / Matte red
- ... VL = Verde lucido / Glossy green
- ... CT = Craquellé Turquoise / Turquoise craquèle

Le Finiture sono illustrate a pag. 187
See Finishings on page 187



IMPIANTO A TRECCIA BRAID SYSTEM

L'impianto a treccia si propone di soddisfare le esigenze di coloro che desiderano ristrutturare ambienti nell'ottica della funzionalità, nella riscoperta delle tradizioni e nella più completa sicurezza in conformità alle norme vigenti. Lasciamoci avvolgere dal calore di questi oggetti e dalle loro forme.

The system with braid is suitable to satisfy each requirement of environment reconstruction considering the functionality, rediscovering traditions and not forgetting security in conformity with the current standard norms. Let us surround by the warmth sensation and shapes of these objects.

Le linee qui di seguito presentate rispondono ad un ideale di signorilità, suscitano ammirazione e piacere estetico, nel rispetto delle tradizioni. La nostra esperienza come produttori di apparecchi per illuminazione è messa a disposizione di progettisti ed installatori e propone valide alternative alle esigenze di ristrutturazione.



These series meet an ideal style, provoke admiration and aesthetic pleasure respecting tradition. We offer our lighting fixtures manufacturers experience to designers and installers and we propose valid alternatives to restructuring requirements.



L'impianto "a treccia" è il corretto connubio tra tecnologia moderna e valore antico. Tutta la magia della luce racchiusa in una linea che illuminerà il vostro sguardo sul mondo.

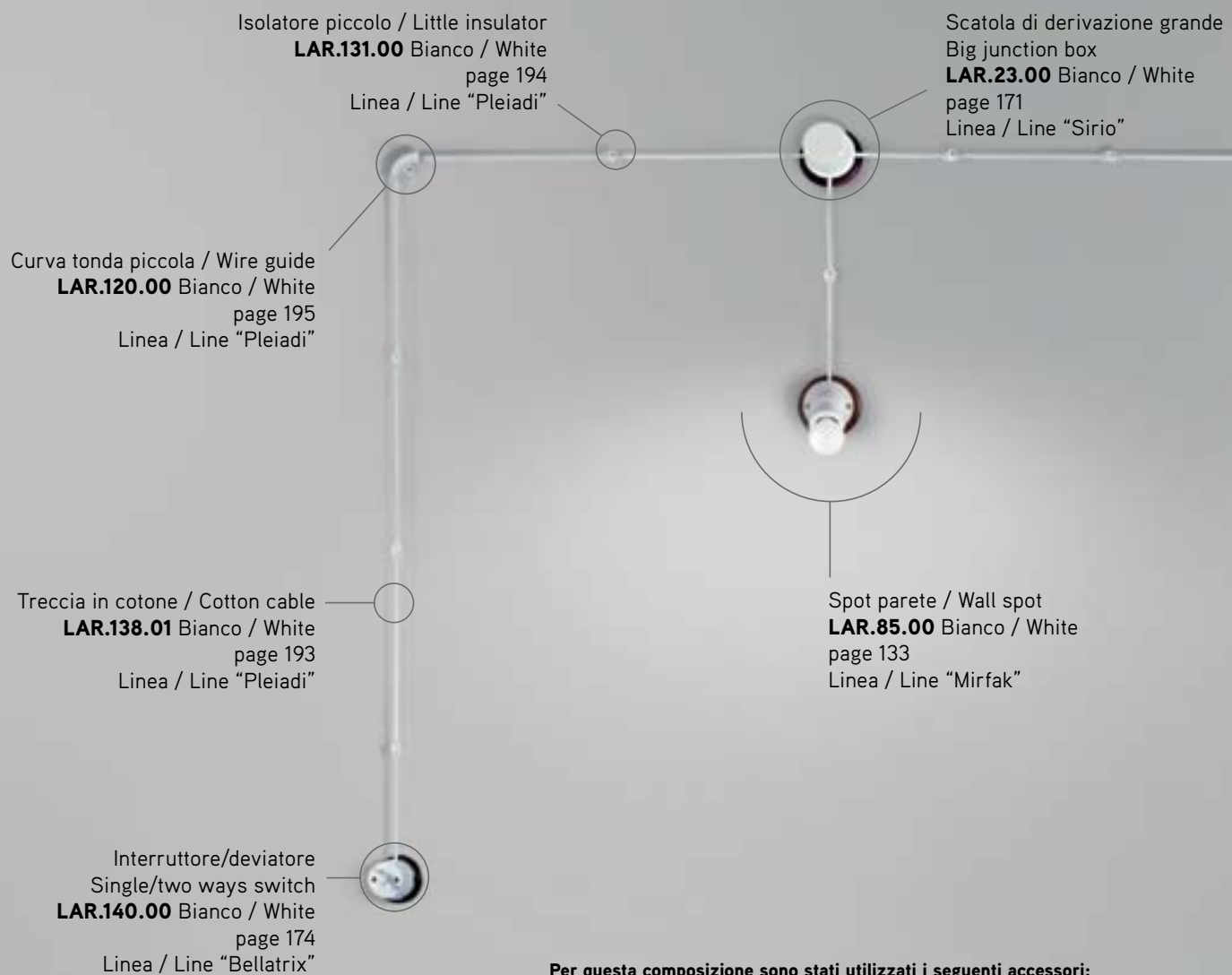

Rosetta legno piccola
Wood little canopy
LAR.134.A
page 196
Linea / Line "Pleiadi"

Per questa composizione sono stati utilizzati i seguenti accessori:

- N° 3 scatole di derivazione in ceramica bianca (**LAR.23.00** linea Sirio)
- N° 2 spot a una luce in ceramica bianca (**LAR.85.00** linea Mirfak)
- N° 5 rosette in legno grandi (**LAR.134.B** linea Pleiadi)
- N° 1 interruttore/deviatore in ceramica bianca (**LAR.140.00** Linea Bellatrix)
- N° 2 interruttori/deviatori in ceramica bianca con farfallina in ottone anticato (**LAR.20.00** linea Sirio)
- N° 3 rosette in legno piccole (**LAR.134.A** linea Pleiadi)
- N° 2 curve rette grandi in ceramica bianca (**LAR.116.00** linea Pleiadi)
- N° 1 curva tonda piccola in ceramica bianca (**LAR.120.00** linea Pleiadi)
- N° 15 isolatori in ceramica bianca (**LAR.131.00** linea Pleiadi)
- N° 3 isolatori doppi in ceramica bianca (**LAR.132.00** linea Pleiadi)
- 7 metri treccia in cotone bianco (**LAR.138.01** sezione 3 x 0,75 linea Pleiadi)

The system with braid is the correct alliance between modern technology and ancient value. The magic of light in a line that brightens up your look upon the world.

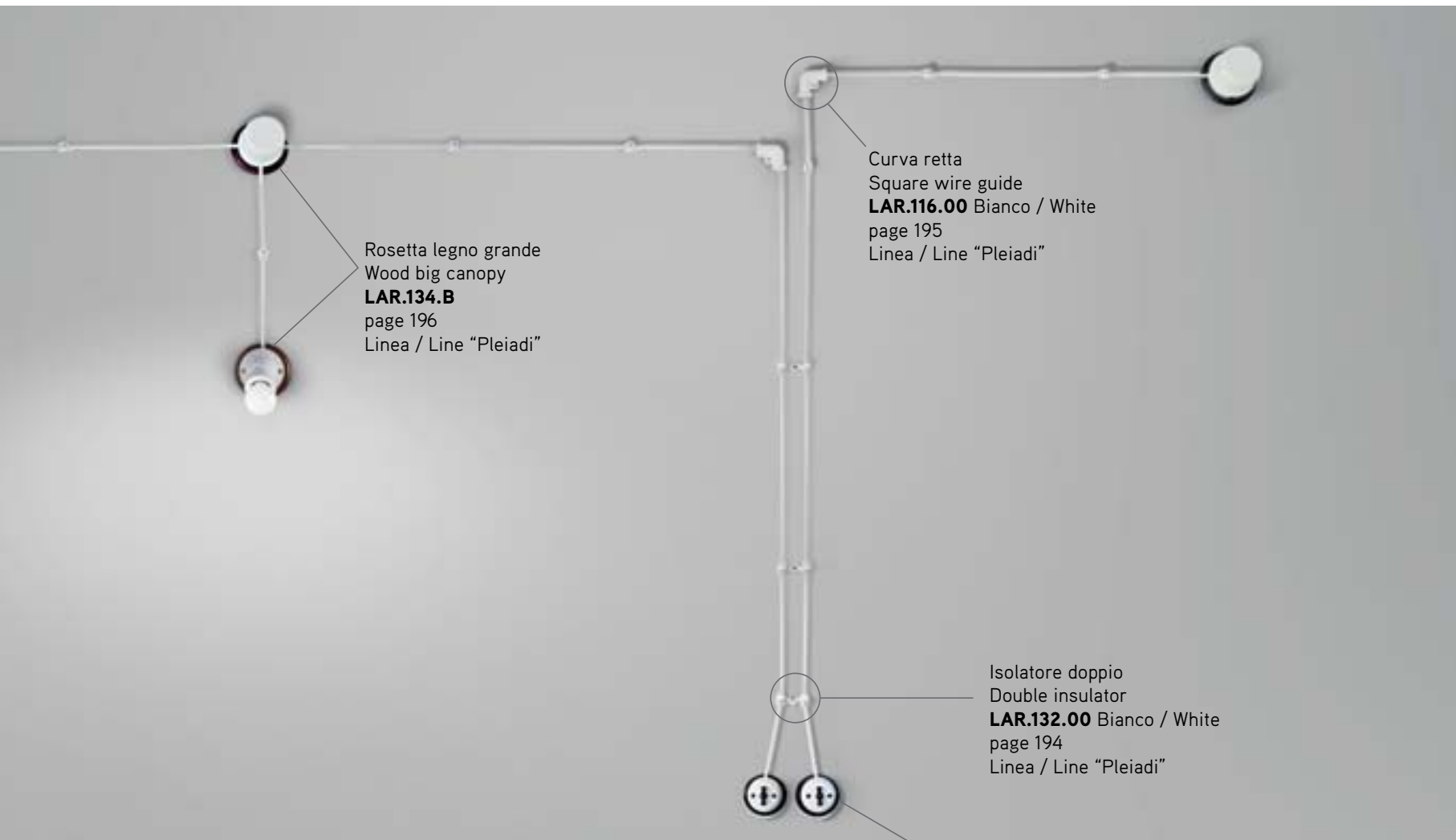

Rosetta legno grande
Wood big canopy
LAR.134.B
page 196
Linea / Line "Pleiadi"

Curva retta
Square wire guide
LAR.116.00 Bianco / White
page 195
Linea / Line "Pleiadi"

Isolatore doppio
Double insulator
LAR.132.00 Bianco / White
page 194
Linea / Line "Pleiadi"

Interruttore/deviatore
Single/two ways switch
LAR.20.00 Bianco / White
page 170
Linea / Line "Sirio"

Rosetta legno piccola
Wood little canopy
LAR.134.A
page 196
Linea / Line "Pleiadi"

To compose this solution has been utilized following articles:

- N° 3 junction box in white ceramic (**LAR.23.00** Sirio line)
- N° 2 spot with one lights in white ceramic (**LAR.85.00** Mirfak line)
- N° 5 wood big canopies (**LAR.134.B** Pleiadi line)
- N° 1 single-two ways switch in white ceramic (**LAR.140.00** Bellatrix line)
- N° 2 single-two ways switch in white ceramic (**LAR.20.00** Sirio line)
- N° 3 wood little canopies (**LAR.134.A** Pleiadi line)
- N° 2 wire guide in white ceramic (**LAR.116.00** Pleiadi line)
- N° 1 wire guide in white ceramic (**LAR.120.00** Pleiadi line)
- N° 15 insulator in white ceramic (**LAR.131.00** Pleiadi line)
- N° 3 double insulator in white ceramic (**LAR.132.00** Pleiadi line)
- 7 mt. white cotton cable (**LAR.138.01** sezione 3 x 0,75 Pleiadi line)

LINEA

Castore

Serie composta da interruttori, prese e scatola di derivazione. Per tutti gli articoli della serie è prevista la variante in ceramica bianca e cotto. Gli articoli della serie sono comprensivi di frutto interno e possono essere corredati con particolari di nostra produzione della serie "Pleiadi", da ordinare a parte.

Ceramic surface mounted switches, sockets and junction box. Articles can be supplied in white ceramic or cotto ceramic. They can be combined with the "Pleiadi" accessories, to be ordered separately.



Art. LAR.187.C
Art. LAR.134.A
Art. LAR.131.C
Art. LAR.138.03



Interruttore / Deviatore Single/two ways switch

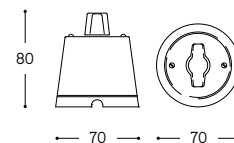

ARTICOLO ITEM	V	A	PESO GR. WEIGHT GR.	VOL. IN M ³ VOL. IN M ³	PEZZI IMBALLO OUTER BOX	FASCIA PREZZO PRICE RANGE
LAR.187.00 Bianco / White	250	10	234	0,001	1	B19
LAR.187.C Cotto / Cotto						



Variatore luminosità Rotary dimmer switch

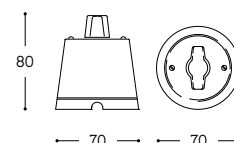

ARTICOLO ITEM	VA	PESO GR. WEIGHT GR.	VOL. IN M ³ VOL. IN M ³	PEZZI IMBALLO OUTER BOX	FASCIA PREZZO PRICE RANGE
LAR.187.00/DIMMER Bianco / White	400	269	0,001	1	B35
LAR.187.C/DIMMER Cotto / Cotto					



Presse bipasso Two ways socket

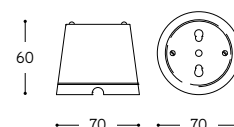

ARTICOLO ITEM	V	A	PESO GR. WEIGHT GR.	VOL. IN M ³ VOL. IN M ³	PEZZI IMBALLO OUTER BOX	FASCIA PREZZO PRICE RANGE
LAR.188.00 Bianco / White	250	16	224	0,001	1	B19
LAR.188.C Cotto / Cotto						



Presse Internet RJ45 Internet socket RJ45

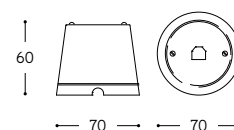

ARTICOLO ITEM	PESO GR. WEIGHT GR.	VOL. IN M ³ VOL. IN M ³	PEZZI IMBALLO OUTER BOX	FASCIA PREZZO PRICE RANGE
LAR.188.00/INTE Bianco / White	222	0,001	1	B35
LAR.188.C/INTE Cotto / Cotto				



Presa telefono RJ11 Telephone socket RJ11

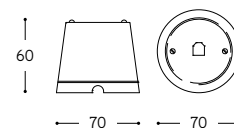

ARTICOLO ITEM	PESO GR. WEIGHT GR.	VOL. IN M ³ VOL. IN M ³	PEZZI IMBALLO OUTER BOX	FASCIA PREZZO PRICE RANGE
LAR.188.00/TEL Bianco / White	210	0,001	1	B19
LAR.188.C/TEL Cotto / Cotto				



Presa coassiale TV/SAT TV/SAT coaxial socket

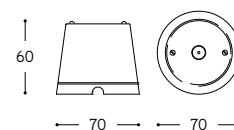

ARTICOLO ITEM	PESO GR. WEIGHT GR.	VOL. IN M ³ VOL. IN M ³	PEZZI IMBALLO OUTER BOX	FASCIA PREZZO PRICE RANGE
LAR.188.00/TV/SAT Bianco / White	214	0,001	1	B19
LAR.188.C/TV/SAT Cotto / Cotto				



Scatola di derivazione Ceramic junction box

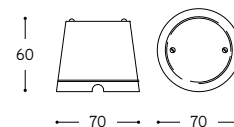

ARTICOLO ITEM	PESO GR. WEIGHT GR.	VOL. IN M ³ VOL. IN M ³	PEZZI IMBALLO OUTER BOX	FASCIA PREZZO PRICE RANGE
LAR.189.00 Bianco / White	202	0,001	1	B13
LAR.189.C Cotto / Cotto				



Art. LAR.191.00
Art. LAR.134.A

Art. LAR.190.00
Art. LAR.134.A

Art. LAR.132.00
Art. LAR.138.02

LINEA Polluce

Serie composta da interruttore, prese e scatola di derivazione. Per tutti gli articoli della serie è prevista la variante in ceramica bianca e cotto. Gli articoli della serie sono comprensivi di frutto interno e possono essere corredati con particolari di nostra produzione della serie "Pleiadi", da ordinare a parte.

Ceramic surface mounted switch, sockets and junction box. Articles can be supplied in white ceramic or cotto ceramic. They can be combined with the "Pleiadi" accessories, to be ordered separately.



Interruttore / Deviatore Single/two ways switch

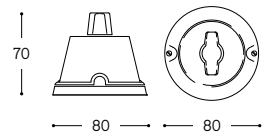

ARTICOLO ITEM	V	A	PESO GR. WEIGHT GR.	VOL. IN M ³ VOL. IN M ³	PEZZI IMBALLO OUTER BOX	FASCIA PREZZO PRICE RANGE
LAR.190.00 Bianco / White	250	10	246	0,001	1	B19
LAR.190.C Cotto / Cotto						



Presa bipasso
Two ways socket

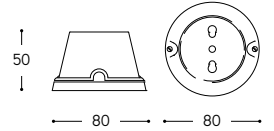

ARTICOLO ITEM	V	A	PESO GR. WEIGHT GR.	VOL. IN M ³ VOL. IN M ³	PEZZI IMBALLO OUTER BOX	FASCIA PREZZO PRICE RANGE
LAR.191.00 Bianco / White	250	16	236	0,001	1	B19
LAR.191.C Cotto / Cotto						



Presa telefono RJ11
Telephone socket RJ11

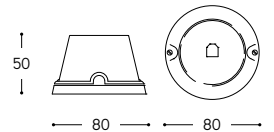

ARTICOLO ITEM	PESO GR. WEIGHT GR.	VOL. IN M ³ VOL. IN M ³	PEZZI IMBALLO OUTER BOX	FASCIA PREZZO PRICE RANGE
LAR.191.00/TEL Bianco / White	216	0,001	1	B19
LAR.191.C/TEL Cotto / Cotto				



Presa coassiale TV/SAT
TV/SAT coaxial socket

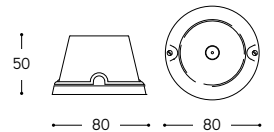

ARTICOLO ITEM	PESO GR. WEIGHT GR.	VOL. IN M ³ VOL. IN M ³	PEZZI IMBALLO OUTER BOX	FASCIA PREZZO PRICE RANGE
LAR.191.00/TV/SAT Bianco / White	230	0,001	1	B19
LAR.191.C/TV/SAT Cotto / Cotto				



Scatola di derivazione
Ceramic junction box

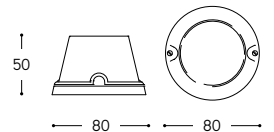

ARTICOLO ITEM	PESO GR. WEIGHT GR.	VOL. IN M ³ VOL. IN M ³	PEZZI IMBALLO OUTER BOX	FASCIA PREZZO PRICE RANGE
LAR.192.00 Bianco / White	216	0,001	1	B13
LAR.192.C Cotto / Cotto				

LINEA
Antares

Serie composta da interruttore/deviatore, prese e scatole di derivazione grande e piccola. I materiali utilizzati sono la ceramica bianca, la ceramica decorata con filo colorato o la ceramica - cotto. Gli articoli della serie sono comprensivi di frutto interno e possono essere corredati con particolari di nostra produzione della serie "Pleiadi", da ordinare a parte.

Ceramic surface mounted switch, sockets and big or little junction box. Articles can be supplied in different versions: white ceramic, coloured line ceramic or cotto ceramic. They can be combined with the "Pleiadi" accessories, to be ordered separately.

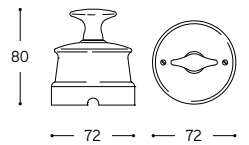
Interruttore / Deviatore
Single/two ways switch

ARTICOLO ITEM	V	A	PESO GR. WEIGHT GR.	VOL. IN M ³ VOL. IN M ³	PEZZI IMBALLO OUTER BOX	FASCIA PREZZO PRICE RANGE
LAR.10.00 Bianco / White						
LAR.10. ... Filo colorato / Coloured line (*)	250	10	240	0,001	1	B30
LAR.10.C Cotto / Cotto						



Presa bipasso Two ways socket

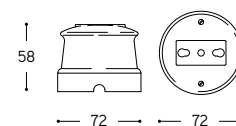

ARTICOLO ITEM	V	A	PESO GR. WEIGHT GR.	VOL. IN M ³ VOL. IN M ³	PEZZI IMBALLO OUTER BOX	FASCIA PREZZO PRICE RANGE
LAR.15.00 Bianco / White						
LAR.15. ... Filo colorato / Coloured line (*)	250	16	224	0,001	1	B23
LAR.15.C Cotto / Cotto						



Presa telefono RJ11 Telephone socket RJ11

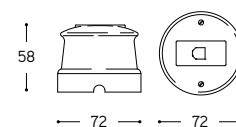

ARTICOLO ITEM	PESO GR. WEIGHT GR.	VOL. IN M ³ VOL. IN M ³	PEZZI IMBALLO OUTER BOX	FASCIA PREZZO PRICE RANGE
LAR.15.00/TEL Bianco / White				
LAR.15. .../TEL Filo colorato / Coloured line (*)	214	0,001	1	B23
LAR.15.C/TEL Cotto / Cotto				



Presa coassiale TV/SAT TV/SAT coaxial socket

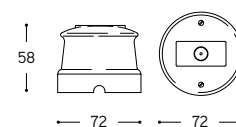

ARTICOLO ITEM	PESO GR. WEIGHT GR.	VOL. IN M ³ VOL. IN M ³	PEZZI IMBALLO OUTER BOX	FASCIA PREZZO PRICE RANGE
LAR.15.00/TV/SAT Bianco / White				
LAR.15. .../TV/SAT Filo colorato / Coloured line (*)	218	0,001	1	B23
LAR.15.C/TV/SAT Cotto / Cotto				



Scatola di derivazione Ceramic junction box

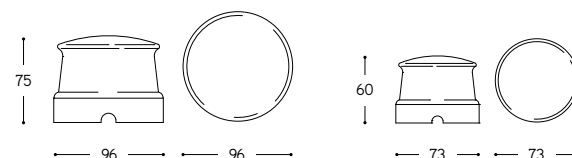

ARTICOLO ITEM	PESO GR. WEIGHT GR.	VOL. IN M ³ VOL. IN M ³	PEZZI IMBALLO OUTER BOX	FASCIA PREZZO PRICE RANGE
LAR.13.00 Grande Bianca / Big White				
LAR.13. ... Grande filo colorato / Big coloured line (*)	354	0,002	1	B19
LAR.13.C Grande Cotto / Big Cotto				
LAR.12.00 Piccola Bianca / Small White				
LAR.12. ... Piccola filo colorato / Small coloured line (*)	188	0,001	1	B13
LAR.12.C Piccola Cotto / Small Cotto				

(*) ... FR = Filo rosso / Red line
 ... FM = Filo marrone / Brown line
 ... FA = Filo ramina / Green line
 ... FB = Filo blu / Blue line
 ... FO = Filo arancio / Orange line

Art. LAR.20.C
Art. LAR.134.A

Art. LAR.131.C
Art. LAR.138.03

LINEA Sirio

Serie composta da interruttore/deviatore, prese e scatole di derivazione grande e piccola. I materiali utilizzati sono la ceramica bianca, la ceramica decorata con filo colorato o la ceramica - cotto. Gli articoli della serie sono comprensivi di frutto interno e possono essere corredati con particolari di nostra produzione della serie "Pleiadi", da ordinare a parte.

Ceramic surface mounted switch, sockets and big or little junction box. Articles can be supplied in different versions: white ceramic, coloured line ceramic or cotto ceramic. They can be combined with the "Pleiadi" accessories, to be ordered separately.



Interruttore / Deviatore Single/two ways switch

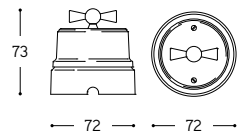

ARTICOLO ITEM	V	A	PESO GR. WEIGHT GR.	VOL. IN M ³ VOL. IN M ³	PEZZI IMBALLO OUTER BOX	FASCIA PREZZO PRICE RANGE
LAR.20.00 Bianco / White						
LAR.20. ... Filo colorato / Coloured line (*)	250	10	260	0,001	1	B30
LAR.20.C Cotto / Cotto						



Presa bipasso Two ways socket

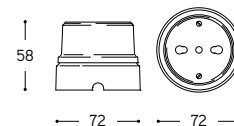

ARTICOLO ITEM	V	A	PESO GR. WEIGHT GR.	VOL. IN M ³ VOL. IN M ³	PEZZI IMBALLO OUTER BOX	FASCIA PREZZO PRICE RANGE
LAR.25.00 Bianco / White						
LAR.25. ... Filo colorato / Coloured line (*)	250	16	242	0,001	1	B23
LAR.25.C Cotto / Cotto						



Presa telefono RJ11 Telephone socket RJ11

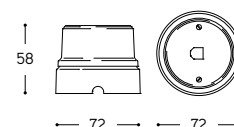

ARTICOLO ITEM	PESO GR. WEIGHT GR.	VOL. IN M ³ VOL. IN M ³	PEZZI IMBALLO OUTER BOX	FASCIA PREZZO PRICE RANGE
LAR.25.00/TEL Bianco / White				
LAR.25. .../TEL Filo colorato / Coloured line (*)	226	0,001	1	B23
LAR.25.C/TEL Cotto / Cotto				



Presa coassiale TV/SAT TV/SAT coaxial socket

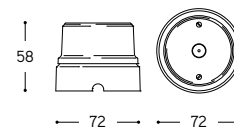

ARTICOLO ITEM	PESO GR. WEIGHT GR.	VOL. IN M ³ VOL. IN M ³	PEZZI IMBALLO OUTER BOX	FASCIA PREZZO PRICE RANGE
LAR.25.00/TV/SAT Bianco / White				
LAR.25. .../TV/SAT Filo colorato / Coloured line (*)	230	0,001	1	B23
LAR.25.C/TV/SAT Cotto / Cotto				



Scatola di derivazione Ceramic junction box

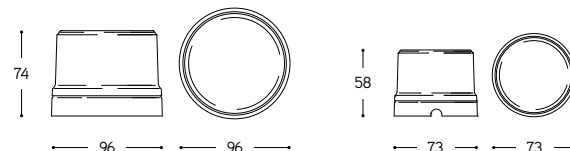

ARTICOLO ITEM	PESO GR. WEIGHT GR.	VOL. IN M ³ VOL. IN M ³	PEZZI IMBALLO OUTER BOX	FASCIA PREZZO PRICE RANGE
LAR.23.00 Grande Bianca / Big White				
LAR.23. ... Grande filo colorato / Big coloured line (*)	346	0,002	1	B19
LAR.23.C Grande Cotto / Big Cotto				
LAR.22.00 Piccola Bianca / Small White				
LAR.22. ... Piccola filo colorato / Small coloured line (*)	198	0,001	1	B13
LAR.22.C Piccola Cotto / Small Cotto				

(*) ... FR = Filo rosso / Red line
 ... FM = Filo marrone / Brown line
 ... FA = Filo ramina / Green line
 ... FB = Filo blu / Blue line
 ... FO = Filo arancio / Orange line

LINEA
Rigel

Serie composta da interruttore/deviatore, prese e scatole di derivazione grande e piccola. I materiali utilizzati sono la ceramica bianca, la ceramica decorata con filo colorato o la ceramica - cotto. Gli articoli della serie sono comprensivi di frutto interno e possono essere corredati con particolari di nostra produzione della serie "Pleiadi", da ordinare a parte.

Ceramic surface mounted switch, sockets and big or little junction box. Articles can be supplied in different versions: white ceramic, coloured line ceramic or cotto ceramic. They can be combined with the "Pleiadi" accessories, to be ordered separately.

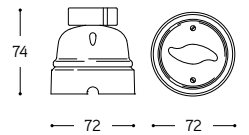
Interruttore / Deviatore
Single/two ways switch

ARTICOLO ITEM	V	A	PESO GR. WEIGHT GR.	VOL. IN M ³ VOL. IN M ³	PEZZI IMBALLO OUTER BOX	FASCIA PREZZO PRICE RANGE
LAR.30.00 Bianco / White						
LAR.30. ... Filo colorato / Coloured line (*)	250	10	234	0,001	1	B30
LAR.30.C Cotto / Cotto						



Presa bipasso Two ways socket

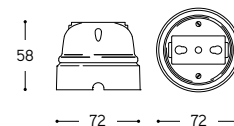

ARTICOLO ITEM	V	A	PESO GR. WEIGHT GR.	VOL. IN M ³ VOL. IN M ³	PEZZI IMBALLO OUTER BOX	FASCIA PREZZO PRICE RANGE
LAR.35.00 Bianco / White						
LAR.35. ... Filo colorato / Coloured line (*)	250	16	222	0,001	1	B23
LAR.35.C Cotto / Cotto						



Presa telefono RJ11 Telephone socket RJ11

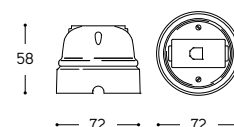

ARTICOLO ITEM	PESO GR. WEIGHT GR.	VOL. IN M ³ VOL. IN M ³	PEZZI IMBALLO OUTER BOX	FASCIA PREZZO PRICE RANGE
LAR.35.00/TEL Bianco / White				
LAR.35. .../TEL Filo colorato / Coloured line (*)	218	0,001	1	B23
LAR.35.C/TEL Cotto / Cotto				



Presa coassiale TV/SAT TV/SAT coaxial socket

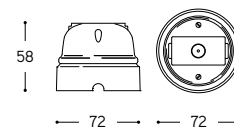

ARTICOLO ITEM	PESO GR. WEIGHT GR.	VOL. IN M ³ VOL. IN M ³	PEZZI IMBALLO OUTER BOX	FASCIA PREZZO PRICE RANGE
LAR.35.00/TV/SAT Bianco / White				
LAR.35. .../TV/SAT Filo colorato / Coloured line (*)	220	0,001	1	B23
LAR.35.C/TV/SAT Cotto / Cotto				



Scatola di derivazione Ceramic junction box

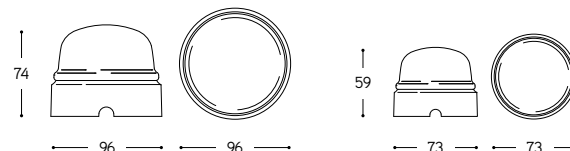

ARTICOLO ITEM	PESO GR. WEIGHT GR.	VOL. IN M ³ VOL. IN M ³	PEZZI IMBALLO OUTER BOX	FASCIA PREZZO PRICE RANGE
LAR.33.00 Grande Bianca / Big White				
LAR.33. ... Grande filo colorato / Big coloured line (*)	320	0,002	1	B19
LAR.33.C Grande Cotto / Big Cotto				
LAR.32.00 Piccola Bianca / Small White				
LAR.32. ... Piccola filo colorato / Small coloured line (*)	192	0,001	1	B13
LAR.32.C Piccola Cotto / Small Cotto				

(*) ... FR = Filo rosso / Red line
 ... FM = Filo marrone / Brown line
 ... FA = Filo ramina / Green line
 ... FB = Filo blu / Blue line
 ... FO = Filo arancio / Orange line

Art. LAR.140.00
Art. LAR.134.A

Art. LAR.138.01
Art. LAR.131.00

LINEA Bellatrix

Serie composta da interruttore, prese e scatola di derivazione. Per tutti gli articoli della serie è prevista la variante in ceramica bianca e cotto. Gli articoli della serie sono comprensivi di frutto interno e possono essere corredati con particolari di nostra produzione della serie "Pleiadi", da ordinare a parte.

Ceramic surface mounted switch, sockets and junction box. Articles can be supplied in white ceramic or cotto ceramic. They can be combined with the "Pleiadi" accessories, to be ordered separately.



Interruttore / Deviatore Single/two ways switch

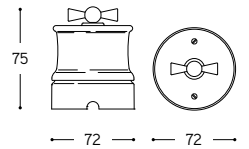

ARTICOLO ITEM	V	A	PESO GR. WEIGHT GR.	VOL. IN M ³ VOL. IN M ³	PEZZI IMBALLO OUTER BOX	FASCIA PREZZO PRICE RANGE
LAR.140.00 Bianco / White						
LAR.140. ... Filo colorato / Coloured line (*)	250	10	234	0,001	1	B30
LAR.140.C Cotto / Cotto						



Presa bipasso
Two ways socket

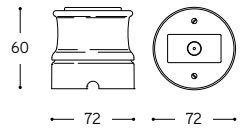

ARTICOLO ITEM	V	A	PESO GR. WEIGHT GR.	VOL. IN M ³ VOL. IN M ³	PEZZI IMBALLO OUTER BOX	FASCIA PREZZO PRICE RANGE
LAR.141.00 Bianco / White						
LAR.141. ... Filo colorato / Coloured line (*)	250	16	230	0,001	1	B23
LAR.141.C Cotto / Cotto						



Presa telefono RJ11
Telephone socket RJ11

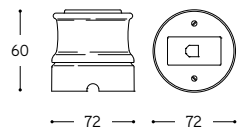

ARTICOLO ITEM	PESO GR. WEIGHT GR.	VOL. IN M ³ VOL. IN M ³	PEZZI IMBALLO OUTER BOX	FASCIA PREZZO PRICE RANGE
LAR.141.00/TEL Bianco / White				
LAR.141. .../TEL Filo colorato / Coloured line (*)	218	0,001	1	B23
LAR.141.C/TEL Cotto / Cotto				



Presa coassiale TV/SAT
TV/SAT coaxial socket

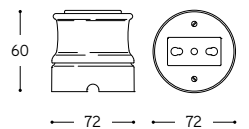

ARTICOLO ITEM	PESO GR. WEIGHT GR.	VOL. IN M ³ VOL. IN M ³	PEZZI IMBALLO OUTER BOX	FASCIA PREZZO PRICE RANGE
LAR.141.00/TV/SAT Bianco / White				
LAR.141. .../TV/SAT Filo colorato / Coloured line (*)	228	0,001	1	B23
LAR.141.C/TV/SAT Cotto / Cotto				



Scatola di derivazione
Ceramic junction box

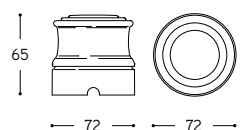

ARTICOLO ITEM	PESO GR. WEIGHT GR.	VOL. IN M ³ VOL. IN M ³	PEZZI IMBALLO OUTER BOX	FASCIA PREZZO PRICE RANGE
LAR.142.00 Bianco / White				
LAR.142. ... Filo colorato / Coloured line (*)	192	0,001	1	B13
LAR.142.C Cotto / Cotto				

(*) ... FR = Filo rosso / Red line
 ... FM = Filo marrone / Brown line
 ... FA = Filo ramina / Green line
 ... FB = Filo blu / Blue line
 ... FO = Filo arancio / Orange line

I Fili colorati sono illustrati a pag. 184
 See Coloured lines on page 184

Art. LAR.ID9.00

LINEA
Meissa

Serie composta da interruttori, prese, una presa tipo Schuko ed una presa standard francese. Per tutti gli articoli della serie è prevista la variante in ceramica bianca e cotto. Gli articoli della serie sono comprensivi di frutto interno. La serie è stata studiata per il montaggio su scatola rotonda da incasso, compresa nell'articolo.

Ceramic surfaces mounted switches, sockets, Schuko socket and French shuttered 2 poles socket. Articles can be supplied in white ceramic or cotto ceramic. The series is designed for included flush mounting round box.

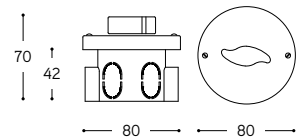
Interruttore / Deviatore
Single/two ways switch

ARTICOLO ITEM	V	A	PESO GR. WEIGHT GR	VOL. IN M ³ VOL. IN M ³	PEZZI IMBALLO OUTER BOX	FASCIA PREZZO PRICE RANGE
LAR.ID9.00 Bianco / White	250	10	144	0,001	1	B19
LAR.ID9.C Cotto / Cotto						

Per un corretto montaggio For correct assembling

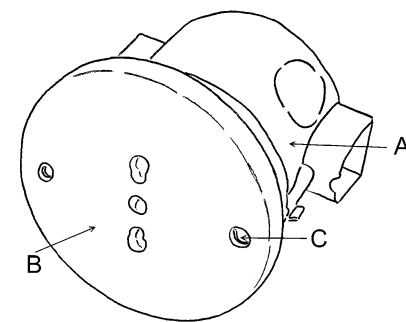

- 1 Fare eseguire l'installazione da personale qualificato.
- 2 L'articolo è composto dal coperchio in gres ceramico (B) comprensivo di presa o interruttore e da relativa scatola tonda da incasso (A).
- 3 Togliere la tensione di rete prima di procedere all'installazione dell'apparecchio.
- 4 Cementare a filo muro la scatola tonda da incasso.
- 5 Collegare i conduttori di rete alla presa o interruttore, rispettando i simboli linea, neutro e terra.
- 6 Chiudere la scatola (A) con il coperchio (B) fissandolo con le viti in dotazione nel punto (C).
- 7 Ripristinare la tensione di rete.
- 8 La nostra azienda declina ogni responsabilità per danni causati da uno scorretto utilizzo o manomissione dell'apparecchio stesso.

- 1 The installation requires a qualified electrician.
- 2 The article consists of the ceramic cover (B) with switch or socket previously fixed and the round flush mounting box (A).
- 3 Before assembling turn off the main power supply.
- 4 Cement wall-line the flush mounting box.
- 5 Connect supply leads to the switch or socket, complying with the symbols line, neutral and hearth.
- 6 Close the round flush mounting box (A) with the cover (B) and fix it with the respective screws in point (C).
- 7 Turn on the main power supply.
- 8 Our firm decline any responsibility for damage caused by incorrect use or tampering with the appliance.



Variatore luminosità
Rotary dimmer switch

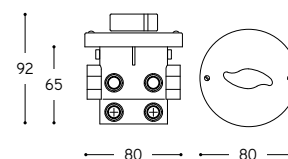

ARTICOLO ITEM	VA	PESO GR. WEIGHT GR.	VOL. IN M ³ VOL. IN M ³	PEZZI IMBALLO OUTER BOX	FASCIA PREZZO PRICE RANGE
LAR.ID9.00/DIMMER Bianco / White	400	196	0,001	1	B35
LAR.ID9.C/DIMMER Cotto / Cotto					



Presa bipasso
Two ways socket

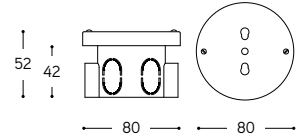

ARTICOLO ITEM	V	A	PESO GR. WEIGHT GR.	VOL. IN M ³ VOL. IN M ³	PEZZI IMBALLO OUTER BOX	FASCIA PREZZO PRICE RANGE
LAR.P13.00 Bianco / White	250	16	146	0,001	1	B8
LAR.P13.C Cotto / Cotto						



Presa telefono RJ11
Telephone socket RJ11

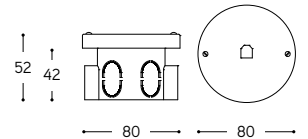

ARTICOLO ITEM	PESO GR. WEIGHT GR.	VOL. IN M ³ VOL. IN M ³	PEZZI IMBALLO OUTER BOX	FASCIA PREZZO PRICE RANGE
LAR.P13.00/TEL Bianco / White	130	0,001	1	B8
LAR.P13.C/TEL Cotto / Cotto				



Presa coassiale TV/SAT
TV/SAT coaxial socket

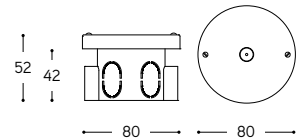

ARTICOLO ITEM	PESO GR. WEIGHT GR.	VOL. IN M ³ VOL. IN M ³	PEZZI IMBALLO OUTER BOX	FASCIA PREZZO PRICE RANGE
LAR.P13.00/TV/SAT Bianco / White	130	0,001	1	B8
LAR.P13.C/TV/SAT Cotto / Cotto				



Presa Schuko
Schuko socket

Presa Francese
French socket

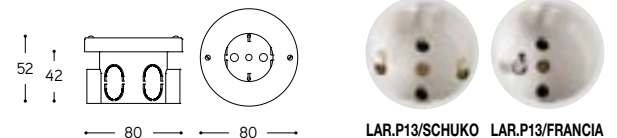

ARTICOLO ITEM	V	A	PESO GR. WEIGHT GR.	VOL. IN M ³ VOL. IN M ³	PEZZI IMBALLO OUTER BOX	FASCIA PREZZO PRICE RANGE
LAR.P13.00/SCHUKO Bianco / White	250	16	162	0,001	1	B8
LAR.P13.C/SCHUKO Cotto / Cotto						
LAR.P13.00/FRANCIA Bianco / White	250	16	162	0,001	1	B8
LAR.P13.C/FRANCIA Cotto / Cotto						

LINEA
Schengen

La linea presenta un modello di presa tipo Schuko ed un modello di presa francese 2 poli, entrambe complete di frutto interno, che possono essere ordinate nelle varianti in ceramica bianca o cotto. Si abbinano facilmente alle altre linee di nostra produzione e possono essere corredate con particolari di nostra produzione della serie "Pleiadi", da ordinare a parte.

Ceramic surface mounted Schuko socket and ceramic surface mounted French shuttered 2 poles socket, both presented in white and cotto ceramic versions. Both articles can be combined with the "Pleiadi" accessories, to be ordered separately.



Preso Schuko
Schuko socket

Preso Francese
French socket

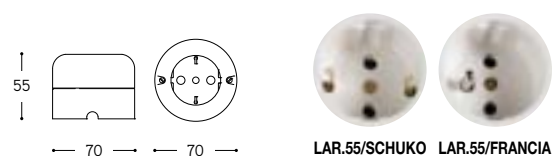

ARTICOLO ITEM	V	A	PESO GR. WEIGHT GR	VOL. IN M ³ VOL. IN M ³	PEZZI IMBALLO OUTER BOX	FASCIA PREZZO PRICE RANGE
LAR.55.00/SCHUKO Bianco / White	250	16	268	0,001	1	B30
LAR.55.C/SCHUKO Cotto / Cotto						
LAR.55.00/FRANCIA Bianco / White	250	16	268	0,001	1	B30
LAR.55.C/FRANCIA Cotto / Cotto						

LINEA Acquario

Serie composta da interruttori, prese, una presa tipo Schuko ed una presa standard francese.

Vanno abbinati alle rispettive cornici da ordinare a parte. Le cornici, di forma ondulata o rotonda, sono previste nelle varianti in ceramica bianca, ingobbio invecchiato ed ingobbio rosso o nella variante in legno. Possono contenere da uno a tre elementi.

Tutti gli articoli di questa linea sono corredati delle rispettive scatole da incasso e frutti interni.

Ceramic surfaces mounted switches, sockets, Schuko socket and French shuttered 2 poles socket. The articles must be combined with the respective frames, to be ordered separately. Frames, round or wavy, can contains one, two or three devices and can be supplied in different versions: white ceramic, red and aged "ingobbio" or wood. The series is supplied with the respective flush mounting boxes.



Per un corretto montaggio

For correct assembling

- 1 Togliere la tensione di rete prima di procedere all'installazione dell'apparecchio. Far eseguire l'installazione da personale qualificato.
 - 2 Cementare a filo muro la scatola da incasso (A).
 - 3 Fissare alla scatola il rispettivo modulo interno (B), utilizzando le viti in dotazione (C).
 - 4 Togliere momentaneamente il pulsante (G) dalla placca in ceramica (E) degli interruttori.
 - 5 Inserire la cornice (D), inserire la placca in ceramica (E) e fissarle entrambe alla scatola di incasso utilizzando le viti in dotazione (F). Rimettere al suo posto il pulsante (G).
 - 6 Ripristinare la tensione di rete.
 - 7 L'eventuale sostituzione o manutenzione degli apparecchi è agevole in quanto è sufficiente allentare le viti, assicurandosi di aver preventivamente tolto la tensione di rete.
 - 8 La nostra azienda declina ogni responsabilità per danni causati da uno scorretto utilizzo o manomissione dell'apparecchio stesso.
-
- 1 Before beginning assembling turn off the main power supply. The installation execution requires the advice of a technician.
 - 2 Cement wall – line the flush mounting box (A).
 - 3 Fix to the box the respective interior module (B), using the respective screws (C).
 - 4 Temporary remove the button (G) from the ceramic cover (E) of switches.
 - 5 Insert the selected frame (D), insert the ceramic cover (E) fixing them to the flush mounting box with the respective screws (F). Replace the button (G).
 - 6 Turn on the main power supply.
 - 7 The possible substitution or maintenance of the equipments is easy as it's sufficient remove screws; make sure to previously turn off the main power supply.
 - 8 Our firm decline any responsibility for damage caused by incorrect use or tampering with the appliance by incorrect use or tampering with the appliance.

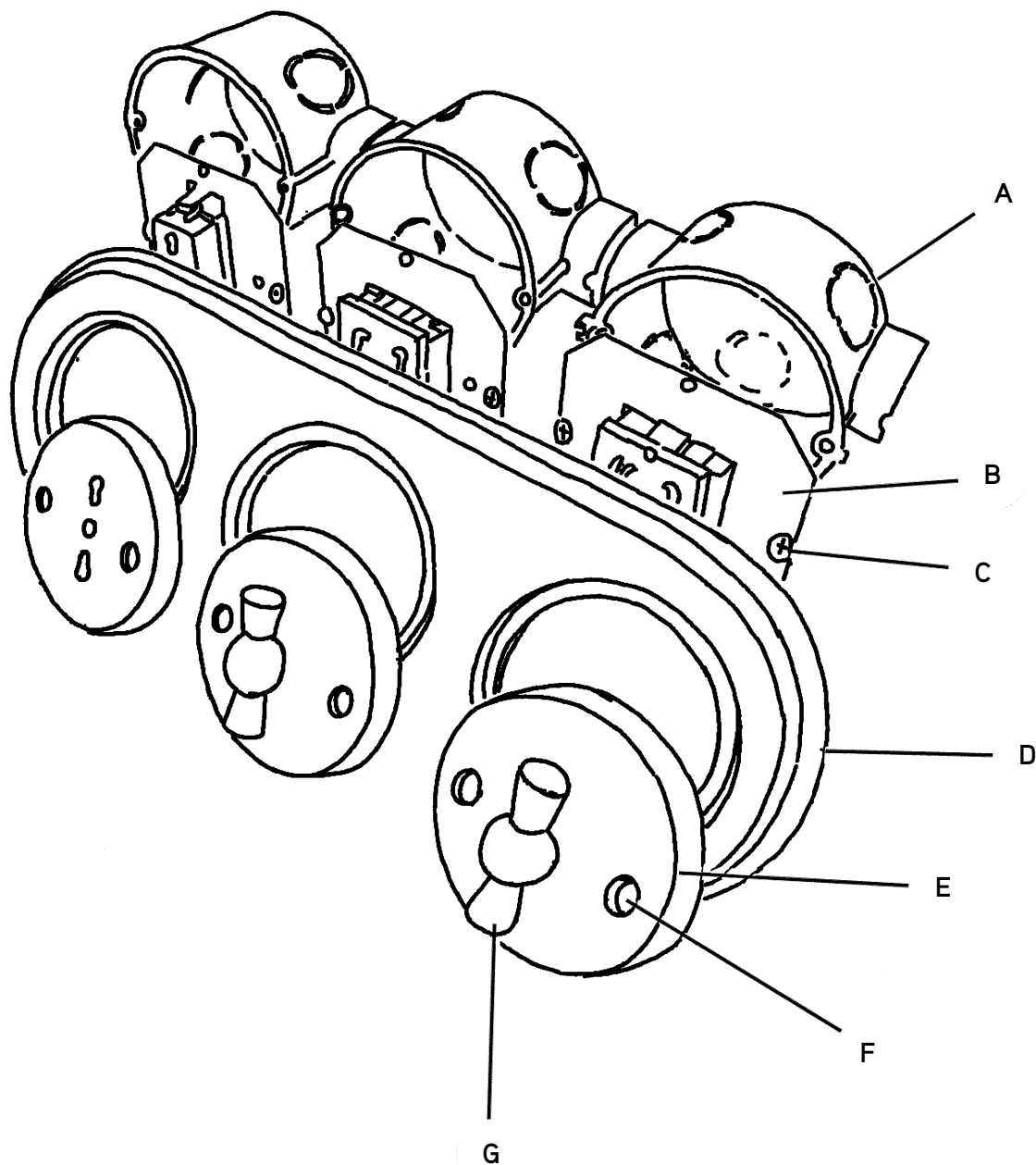



Interruttore / Deviatore Single/two ways switch

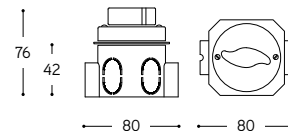

ARTICOLO ITEM	V	A	PESO GR. WEIGHT GR	VOL. IN M ³ VOL. IN M ³	PEZZI IMBALLO OUTER BOX	FASCIA PREZZO PRICE RANGE
LAR.ID1.00 Bianco / White	250	10	158	0,001	1	B19
LAR.ID1.C Cotto / Cotto						



Interruttore / Deviatore con farfallina ottone anticato Single/two ways switch with aged brass button

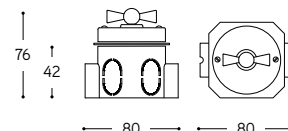

ARTICOLO ITEM	V	A	PESO GR. WEIGHT GR	VOL. IN M ³ VOL. IN M ³	PEZZI IMBALLO OUTER BOX	FASCIA PREZZO PRICE RANGE
LAR.ID2.00 Bianco / White	250	10	176	0,001	1	B19
LAR.ID2.C Cotto / Cotto						



Variatore luminosità Rotary dimmer switch

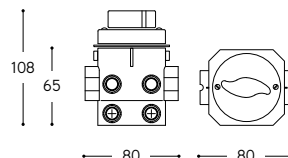

ARTICOLO ITEM	VA	PESO GR. WEIGHT GR.	VOL. IN M ³ VOL. IN M ³	PEZZI IMBALLO OUTER BOX	FASCIA PREZZO PRICE RANGE
LAR.ID1.00/DIMMER Bianco / White	400	206	0,001	1	B35
LAR.ID1.C/DIMMER Cotto / Cotto					



Presse bipasso Two ways socket

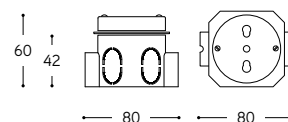

ARTICOLO ITEM	V	A	PESO GR. WEIGHT GR	VOL. IN M ³ VOL. IN M ³	PEZZI IMBALLO OUTER BOX	FASCIA PREZZO PRICE RANGE
LAR.P1.00 Bianco / White	250	16	148	0,001	1	B8
LAR.P1.C Cotto / Cotto						



Presa Internet RJ45
Internet socket

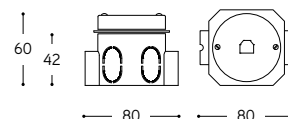

ARTICOLO ITEM	PESO GR. WEIGHT GR.	VOL. IN M ³ VOL. IN M ³	PEZZI IMBALLO OUTER BOX	FASCIA PREZZO PRICE RANGE
LAR.P1.00/INTE Bianco / White	148	0,001	1	B33
LAR.P1.C/INTE Cotto / Cotto				



Presa telefono RJ11
Telephone socket RJ11

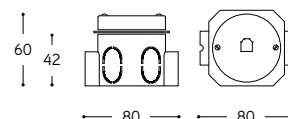

ARTICOLO ITEM	PESO GR. WEIGHT GR.	VOL. IN M ³ VOL. IN M ³	PEZZI IMBALLO OUTER BOX	FASCIA PREZZO PRICE RANGE
LAR.P1.00/TEL Bianco / White	142	0,001	1	B8
LAR.P1.C/TEL Cotto / Cotto				



Presa coassiale TV/SAT
TV/SAT coaxial socket

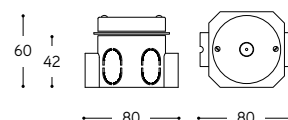

ARTICOLO ITEM	PESO GR. WEIGHT GR.	VOL. IN M ³ VOL. IN M ³	PEZZI IMBALLO OUTER BOX	FASCIA PREZZO PRICE RANGE
LAR.P1.00/TV/SAT Bianco / White	142	0,001	1	B8
LAR.P1.C/TV/SAT Cotto / Cotto				



Presa Schuko
Schuko socket

Presa Francese
French socket

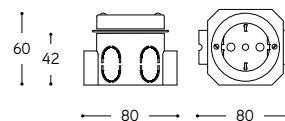

LAR.P1/SCHUKO LAR.P1/FRANCIA

ARTICOLO ITEM	V	A	PESO GR. WEIGHT GR.	VOL. IN M ³ VOL. IN M ³	PEZZI IMBALLO OUTER BOX	FASCIA PREZZO PRICE RANGE
LAR.P1.00/SCHUKO Bianco / White	250	16	174	0,001	1	B8
LAR.P1.C/SCHUKO Cotto / Cotto						
LAR.P1.00/FRANCIA Bianco / White	250	16	174	0,001	1	B8
LAR.P1.C/FRANCIA Cotto / Cotto						



Cornice ondulata in ceramica
1 posizione
Ceramic wavy frame
1 position

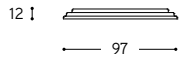
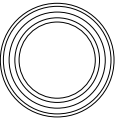

ARTICOLO ITEM	PESO GR. WEIGHT GR.	VOL. IN M ³ VOL. IN M ³	PEZZI IMBALLO OUTER BOX	FASCIA PREZZO PRICE RANGE
OND1 Bianco / White				B12
OND7 Ingobbio invecchiato / Aged "Ingobbio"	120	0,002	1	B14
OND10 Ingobbio rosso / Red "Ingobbio"				B14



Cornice ondulata in ceramica
2 posizioni
Ceramic wavy frame
2 positions

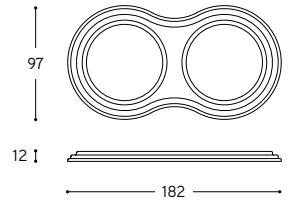

ARTICOLO ITEM	PESO GR. WEIGHT GR.	VOL. IN M ³ VOL. IN M ³	PEZZI IMBALLO OUTER BOX	FASCIA PREZZO PRICE RANGE
OND2 Bianco / White				B19
OND8 Ingobbio invecchiato / Aged "Ingobbio"	260	0,004	1	B21
OND11 Ingobbio rosso / Red "Ingobbio"				B21



Cornice ondulata in ceramica
3 posizioni
Ceramic wavy frame
3 positions

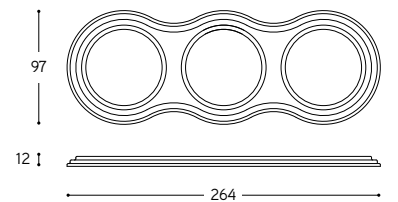

ARTICOLO ITEM	PESO GR. WEIGHT GR.	VOL. IN M ³ VOL. IN M ³	PEZZI IMBALLO OUTER BOX	FASCIA PREZZO PRICE RANGE
OND3 Bianco / White				B23
OND9 Ingobbio invecchiato / Aged "Ingobbio"	356	0,004	1	B30
OND12 Ingobbio rosso / Red "Ingobbio"				B30





Cornice ondulata in legno
1 posizione
Wood wavy frame
1 position

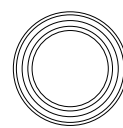

12 I
— 97 —

ARTICOLO ITEM	PESO GR. WEIGHT GR.	VOL. IN M ³ VOL. IN M ³	PEZZI IMBALLO OUTER BOX	FASCIA PREZZO PRICE RANGE
OND13 Finitura ciliegio / Cherry finish	74	0,002	1	B6



Cornice ondulata in legno
2 posizioni
Wood wavy frame
2 positions

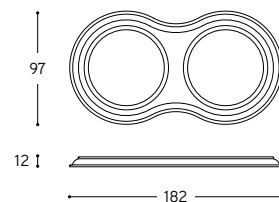

12 I
— 182 —

ARTICOLO ITEM	PESO GR. WEIGHT GR.	VOL. IN M ³ VOL. IN M ³	PEZZI IMBALLO OUTER BOX	FASCIA PREZZO PRICE RANGE
OND14 Finitura ciliegio / Cherry finish	182	0,004	1	B10



Cornice ondulata in legno
3 posizioni
Wood wavy frame
3 positions

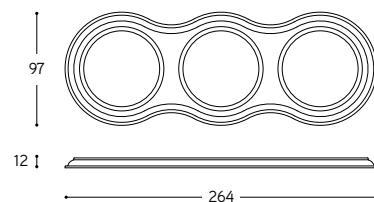

12 I
— 264 —

ARTICOLO ITEM	PESO GR. WEIGHT GR.	VOL. IN M ³ VOL. IN M ³	PEZZI IMBALLO OUTER BOX	FASCIA PREZZO PRICE RANGE
OND15 Finitura ciliegio / Cherry finish	216	0,004	1	B14





Cornice tonda in ceramica
1 posizione
Ceramic round frame
1 position

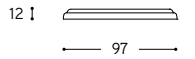
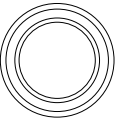

ARTICOLO ITEM	PESO GR. WEIGHT GR.	VOL. IN M ³ VOL. IN M ³	PEZZI IMBALLO OUTER BOX	FASCIA PREZZO PRICE RANGE
RO1 Bianco / White				B12
RO7 Ingobbio invecchiato / Aged "Ingobbio"	126	0,002	1	B14
RO10 Ingobbio rosso / Red "Ingobbio"				B14



Cornice tonda in ceramica
2 posizioni
Ceramic round frame
2 positions

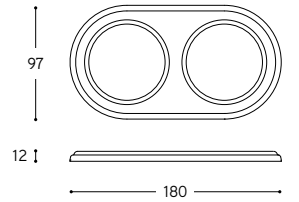

ARTICOLO ITEM	PESO GR. WEIGHT GR.	VOL. IN M ³ VOL. IN M ³	PEZZI IMBALLO OUTER BOX	FASCIA PREZZO PRICE RANGE
RO2 Bianco / White				B19
RO8 Ingobbio invecchiato / Aged "Ingobbio"	304	0,004	1	B21
RO11 Ingobbio rosso / Red "Ingobbio"				B21



Cornice tonda in ceramica
3 posizioni
Ceramic round frame
3 positions

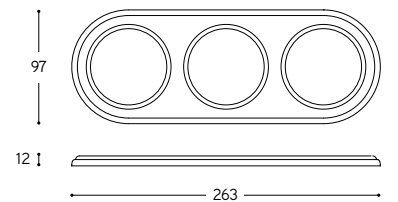

ARTICOLO ITEM	PESO GR. WEIGHT GR.	VOL. IN M ³ VOL. IN M ³	PEZZI IMBALLO OUTER BOX	FASCIA PREZZO PRICE RANGE
RO3 Bianco / White				B23
RO9 Ingobbio invecchiato / Aged "Ingobbio"	408	0,004	1	B30
RO12 Ingobbio rosso / Red "Ingobbio"				B30





Cornice tonda in legno
1 posizione
Wood round frame
1 position

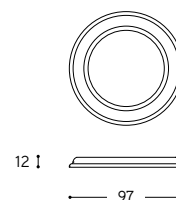

ARTICOLO ITEM	PESO GR. WEIGHT GR.	VOL. IN M ³ VOL. IN M ³	PEZZI IMBALLO OUTER BOX	FASCIA PREZZO PRICE RANGE
RO13 Finitura ciliegio / Cherry finish	74	0,002	1	B6



Cornice tonda in legno
2 posizioni
Wood round frame
2 positions

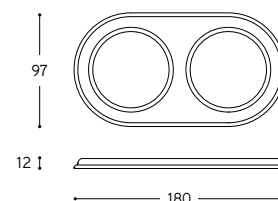

ARTICOLO ITEM	PESO GR. WEIGHT GR.	VOL. IN M ³ VOL. IN M ³	PEZZI IMBALLO OUTER BOX	FASCIA PREZZO PRICE RANGE
RO14 Finitura ciliegio / Cherry finish	184	0,004	1	B10



Cornice tonda in legno
3 posizioni
Wood round frame
3 positions

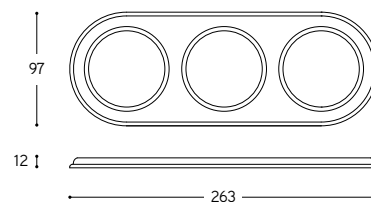

ARTICOLO ITEM	PESO GR. WEIGHT GR.	VOL. IN M ³ VOL. IN M ³	PEZZI IMBALLO OUTER BOX	FASCIA PREZZO PRICE RANGE
RO15 Finitura ciliegio / Cherry finish	226	0,004	1	B14

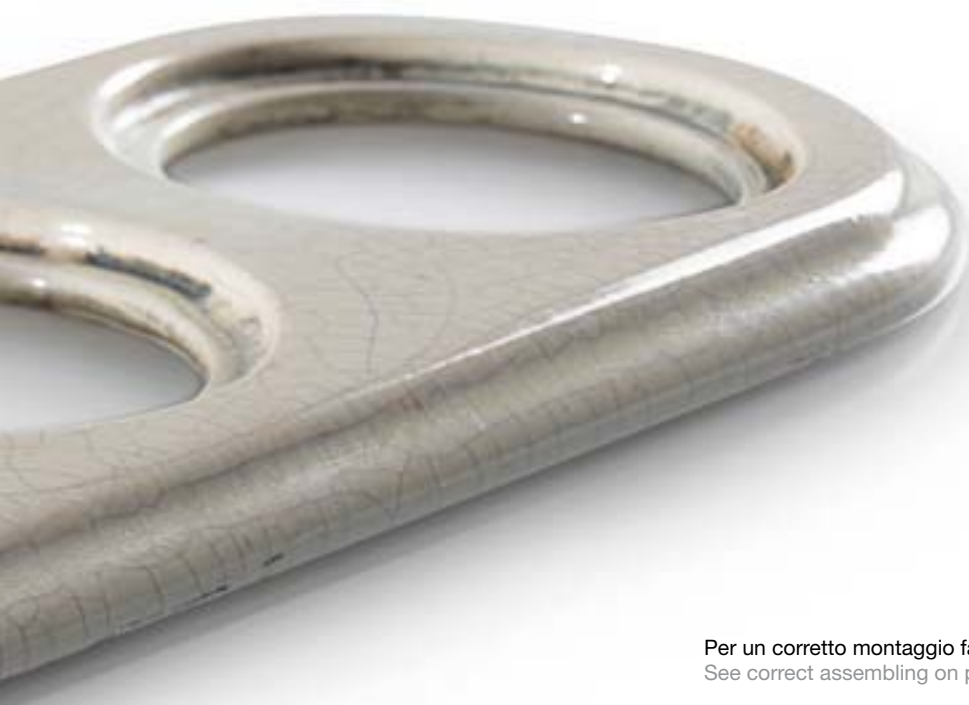

Art. LAR.INT.FB.03
Art. LAR.134.A

Art. LAR.131.00
Art. LAR.138.06

LINEA Mimosa

Serie composta da interruttore/deviatore, scatola di derivazione e custodie da parete per prese o interruttori. Quest'ultimo articolo è comprensivo di frutto interno. I materiali utilizzati sono la ceramica bianca, la ceramica decorata con filo colorato o la ceramica - cotto. Gli articoli della serie possono essere corredati con particolari di nostra produzione della serie "Pleiadi", da ordinare a parte.

Ceramic surface cases for socket and switches, ceramic surface mounted switch and junction box. Articles can be supplied in different versions: white ceramic, coloured line ceramic or cotto ceramic. They can be combined with the "Pleiadi" accessories, to be ordered separately.



Interruttore / Deviatore Single/two ways switch

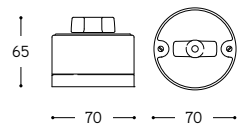

ARTICOLO ITEM	V	A	PESO GR. WEIGHT GR.	VOL. IN M ³ VOL. IN M ³	PEZZI IMBALLO OUTER BOX	FASCIA PREZZO PRICE RANGE
LAR.INT.00.01 Bianco / White						
LAR.INT.01 Filo colorato / Coloured line (*)	250	10	236	0,001	1	B21
LAR.INT.C.01 Cotto / Cotto						



Interruttore / Deviatore Single/two ways switch

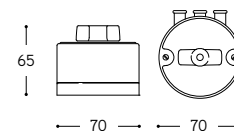

ARTICOLO ITEM	V	A	PESO GR. WEIGHT GR.	VOL. IN M ³ VOL. IN M ³	PEZZI IMBALLO OUTER BOX	FASCIA PREZZO PRICE RANGE
LAR.INT.00.03 Bianco / White						
LAR.INT.03 Filo colorato / Coloured line (*)	250	10	238	0,001	1	B23
LAR.INT.C.03 Cotto / Cotto						



Custodia da parete per prese ed interruttori (**) Surface cases for socket and switches (**)

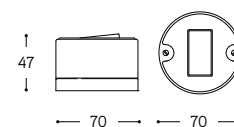

ARTICOLO ITEM	V	A	PESO GR. WEIGHT GR.	VOL. IN M ³ VOL. IN M ³	PEZZI IMBALLO OUTER BOX	FASCIA PREZZO PRICE RANGE
LAR.PRE.00.01 Bianco / White						
LAR.PRE.01 Filo colorato / Coloured line (*)	250	16	218	0,001	1	B19
LAR.PRE.C.01 Cotto / Cotto						



Custodia da parete per prese ed interruttori (**) Surface cases for socket and switches (**)

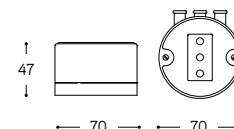

ARTICOLO ITEM	V	A	PESO GR. WEIGHT GR.	VOL. IN M ³ VOL. IN M ³	PEZZI IMBALLO OUTER BOX	FASCIA PREZZO PRICE RANGE
LAR.PRE.00.03 Bianco / White						
LAR.PRE.03 Filo colorato / Coloured line (*)	250	16	222	0,001	1	B21
LAR.PRE.C.03 Cotto / Cotto						



Scatola di derivazione Ceramic junction box

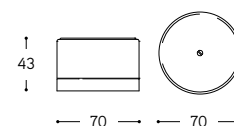

ARTICOLO ITEM	V	A	PESO GR. WEIGHT GR.	VOL. IN M ³ VOL. IN M ³	PEZZI IMBALLO OUTER BOX	FASCIA PREZZO PRICE RANGE
LAR.DER.00						
LAR.DER. ... Filo colorato / Coloured line (*)			200	0,001	1	B19
LAR.DER.C Cotto / Cotto						

(**) Gli interruttori/prese della serie LAR.PRE sono predisposti per apparecchi della serie VIMAR 8000 che non vengono forniti con l'articolo
Switches/socket of LAR.PRE series are arranged for devices VIMAR 8000 series that are not included in the article

I Fili colorati sono illustrati a pag. 184
See Coloured lines on page 184

(*) ... FR = Filo rosso / Red line
... FM = Filo marrone / Brown line
... FA = Filo ramina / Green line
... FB = Filo blu / Blue line
... FO = Filo arancio / Orange line

LINEA Pleiadi

Questa serie di accessori integra l'impianto a treccia ed è composta da rosoni in ceramica, contro basi in legno, passafilo lineari, passafilo a curva retta o tonda, isolatori singoli a due misure, isolatori doppi, treccia cotone e placche in ceramica.

L'articolo "placca" è solo predisposto per moduli delle serie "MAGIC o MATIX B.TICINO", "VIMAR IDEA" e "VIMAR PLANA" che quindi non vengono forniti con l'articolo ordinato.

I materiali utilizzati sono la ceramica bianca, la ceramica decorata con filo colorato e la ceramica-cotto.

This series of accessories integrates the system with cotton braid and is composed of ceiling roses, wood cover for ceramic bases, wire guide in white or cotto ceramic, single or double insulators, twisted cloth cord and ceramic plates.

The article "plate" is only arranged for modules of the series "MAGIC or MATIX B.TICINO", "VIMAR IDEA" and "VIMAR PLANA" that are not provided with the item ordered.

The materials used are white or cotto ceramic and decorated ceramic with colored line.





Passafilo in ceramica Wire guide in ceramic

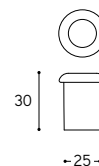

ARTICOLO ITEM	PESO GR. WEIGHT GR	VOL. IN M ³ VOL. IN M ³	PEZZI IMBALLO OUTER BOX	FASCIA PREZZO PRICE RANGE
LAR.133.00 Bianco / White	278	0,001	18	B33
LAR.133.C Cotto / Cotto				



Treccia in cotone Cotton braid

Pezzo singolo / Single pc

ARTICOLO ITEM	SEZ. IN MM SECT. IN MM	PESO GR. WEIGHT GR.	VOL. IN M ³ VOL. IN M ³	PEZZI IMBALLO OUTER BOX	FASCIA PREZZO PRICE RANGE
LAR.138.01/MT. Bianco / White					
LAR.138.03/MT. Marrone / Brown	3 x 0,75	103	0,001	1 mt.	B4
LAR.138.05/MT. Avorio / Ivory					
LAR.138.07/MT. Oro / Gold					
LAR.138.09/MT. Bianco / White					
LAR.138.10/MT. Marrone / Brown	3 x 1,50	138	0,001	1 mt.	B5
LAR.138.11/MT. Avorio / Ivory					
LAR.138.12/MT. Oro / Gold					
LAR.138.02/MT. Bianco / White					
LAR.138.04/MT. Marrone / Brown	3 x 2,50	168	0,001	1 mt.	B9
LAR.138.06/MT. Avorio / Ivory					
LAR.138.08/MT. Oro / Gold					

Confezione 50 mt / 50 m roll

ARTICOLO ITEM	SEZ. IN MM SECT. IN MM	PESO GR. WEIGHT GR.	VOL. IN M ³ VOL. IN M ³	PEZZI IMBALLO OUTER BOX	FASCIA PREZZO PRICE RANGE
LAR.138.01/CONF. Bianco / White					
LAR.138.03/CONF. Marrone / Brown	3 x 0,75	2.720	0,02	1 matassa da 50 mt. 50 m roll	B66
LAR.138.05/CONF. Avorio / Ivory					
LAR.138.07/CONF. Oro / Gold					
LAR.138.09/CONF. Bianco / White					
LAR.138.10/CONF. Marrone / Brown	3 x 1,50	4.520	0,02	1 matassa da 50 mt. 50 m roll	B78
LAR.138.11/CONF. Avorio / Ivory					
LAR.138.12/CONF. Oro / Gold					
LAR.138.02/CONF. Bianco / White					
LAR.138.04/CONF. Marrone / Brown	3 x 2,50	6.000	0,02	1 matassa da 50 mt. 50 m roll	B91
LAR.138.06/CONF. Avorio / Ivory					
LAR.138.08/CONF. Oro / Gold					



Isolatore piccolo / Little insulator

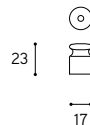

Pezzo singolo / Single pc

ARTICOLO ITEM	PESO GR. WEIGHT GR	VOL. IN M ³ VOL. IN M ³	PEZZI IMBALLO OUTER BOX	FASCIA PREZZO PRICE RANGE
LAR.131.00/ISO Bianco / White	8	0,001	1	B3
LAR.131.C/ISO Cotto / Cotto				

Confezione 50 pezzi / 50 pack

ARTICOLO ITEM	PESO GR. WEIGHT GR	VOL. IN M ³ VOL. IN M ³	PEZZI IMBALLO OUTER BOX	FASCIA PREZZO PRICE RANGE
LAR.131.00/CONF. Bianco / White	548	0,004	50	B43
LAR.131.C/CONF. Cotto / Cotto				



Isolatore grande Big insulator

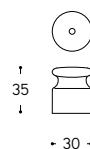

ARTICOLO ITEM	PESO GR. WEIGHT GR	VOL. IN M ³ VOL. IN M ³	PEZZI IMBALLO OUTER BOX	FASCIA PREZZO PRICE RANGE
LAR.130.00 Bianco / White	480	0,001	10	B33
LAR.130.C Cotto / Cotto				



Isolatore doppio Double insulator

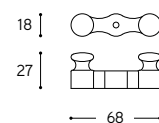

ARTICOLO ITEM	PESO GR. WEIGHT GR	VOL. IN M ³ VOL. IN M ³	PEZZI IMBALLO OUTER BOX	FASCIA PREZZO PRICE RANGE
LAR.132.00 Bianco / White	558	0,001	15	B43
LAR.132.C Cotto / Cotto				



ISOLATORE DOPPIO
DOUBLE INSULATOR



Curva retta
Square wire guide

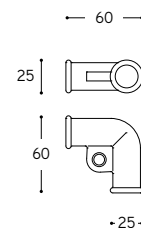

ARTICOLO ITEM	PESO GR. WEIGHT GR	VOL. IN M ³ VOL. IN M ³	PEZZI IMBALLO OUTER BOX	FASCIA PREZZO PRICE RANGE
LAR.116.00 Bianco / White	340	0,001	6	B37
LAR.116.C Cotto / Cotto				



Curva tonda piccola
Little round wire guide

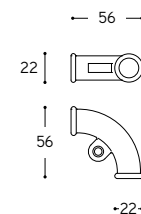

ARTICOLO ITEM	PESO GR. WEIGHT GR	VOL. IN M ³ VOL. IN M ³	PEZZI IMBALLO OUTER BOX	FASCIA PREZZO PRICE RANGE
LAR.120.00 Bianco / White	320	0,001	8	B37
LAR.120.C Cotto / Cotto				



Curva tonda grande
Big round wire guide

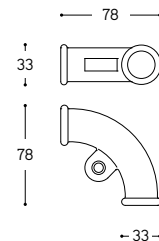

ARTICOLO ITEM	PESO GR. WEIGHT GR	VOL. IN M ³ VOL. IN M ³	PEZZI IMBALLO OUTER BOX	FASCIA PREZZO PRICE RANGE
LAR.126.00 Bianco / White	414	0,002	4	B33
LAR.126.C Cotto / Cotto				



CURVA RETTA
WIRE GUIDE



Rosette in legno Wood canopies

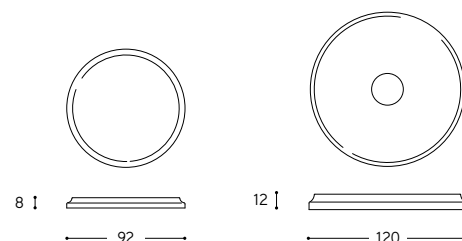

ARTICOLO ITEM	PESO GR. WEIGHT GR	VOL. IN M ³ VOL. IN M ³	PEZZI IMBALLO OUTER BOX	FASCIA PREZZO PRICE RANGE
LAR.134.A Piccola / Little	248	0,001	4	B13
LAR.134.B Grande / Big	414	0,002	4	B13



Rosone per decentramento Roses

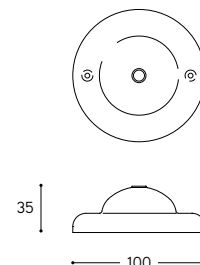

ARTICOLO ITEM	PESO GR. WEIGHT GR.	VOL. IN M ³ VOL. IN M ³	PEZZI IMBALLO OUTER BOX	FASCIA PREZZO PRICE RANGE
LAR.02.00 Bianco / White				
LAR.02. ... Filo colorato / Coloured line (*)	166	0,002	1	B8
LAR.02.C Cotto / Cotto				



Rosone per decentramento Roses

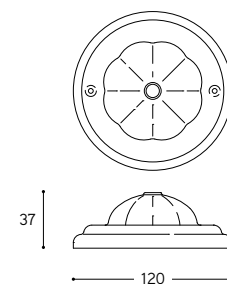

ARTICOLO ITEM	PESO GR. WEIGHT GR.	VOL. IN M ³ VOL. IN M ³	PEZZI IMBALLO OUTER BOX	FASCIA PREZZO PRICE RANGE
LAR.05.00 Bianco / White				
LAR.05. ... Filo colorato / Coloured line (*)	206	0,002	1	B8
LAR.05.C Cotto / Cotto				

- (*) ... **FR** = Filo rosso / Red line
 ... **FM** = Filo marrone / Brown line
 ... **FA** = Filo ramina / Green line
 ... **FB** = Filo blu / Blue line
 ... **FO** = Filo arancio / Orange line

Per un corretto montaggio fare riferimento alle istruzioni presenti a pag. 182-183
 See correct assembling on page 182-183

I Fili colorati sono illustrati a pag. 184
 See Coloured lines on page 184



Design Studio Leonardo Emiliozzi

Placca 3 posti
per moduli B. Ticino MATIX (**)
Three - opening plate
for B. Ticino MATIX modules (**)

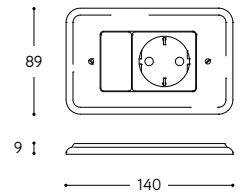

ARTICOLO ITEM	PESO GR. WEIGHT GR.	VOL. IN M ³ VOL. IN M ³	PEZZI IMBALLO OUTER BOX	FASCIA PREZZO PRICE RANGE
1PMTT.00 Bianco / White	200	0,002	1	B10
1PMTT. ... Filo colorato / Coloured line (*)				



Design Studio Leonardo Emiliozzi

Placca per modulo Schuko
B. Ticino MATIX (**)
Plate for Schuko
B. Ticino MATIX module (**)

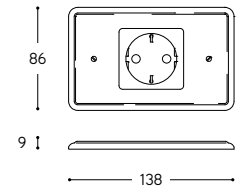

ARTICOLO ITEM	PESO GR. WEIGHT GR.	VOL. IN M ³ VOL. IN M ³	PEZZI IMBALLO OUTER BOX	FASCIA PREZZO PRICE RANGE
1PM.S.00 Bianco / White	200	0,002	1	B10
1PM.S. ... Filo colorato / Coloured line (*)				
1PM.S.C Cotto / Cotto				



Placca 3 posti
per moduli Vimar IDEA (**)
Three - opening plate
for Vimar IDEA modules (**)

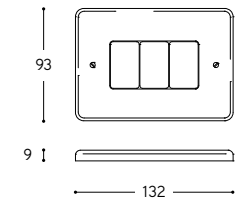

ARTICOLO ITEM	PESO GR. WEIGHT GR.	VOL. IN M ³ VOL. IN M ³	PEZZI IMBALLO OUTER BOX	FASCIA PREZZO PRICE RANGE
1PMIDEA.00 Bianco / White	220	0,002	1	B10
1PMIDEA. ... Filo colorato / Coloured line (*)				



Placca 3 posti
per moduli Vimar PLANA (**)
Three - opening plate
for Vimar PLANA modules (**)

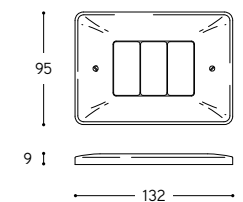

ARTICOLO ITEM	PESO GR. WEIGHT GR.	VOL. IN M ³ VOL. IN M ³	PEZZI IMBALLO OUTER BOX	FASCIA PREZZO PRICE RANGE
1PMPLANA.00 Bianco / White	220	0,002	1	B10

(*) ... **FR** = Filo rosso / Red line
 ... **FM** = Filo marrone / Brown line
 ... **FA** = Filo ramina / Green line
 ... **FB** = Filo blu / Blue line
 ... **FO** = Filo arancio / Orange line

(**) **I moduli B. Ticino MATIX, Vimar IDEA e Vimar PLANA non sono compresi nell'articolo**
B. Ticino MATIX modules, Vimar IDEA and Vimar PLANA modules are not provided with the article

I Fili colorati sono illustrati a pag. 184
 See Coloured lines on page 184

Design Studio Leonardo Emiliozzi



Placca 1 posto
per modulo B. Ticino MAGIC (**)
One - opening plate
for B. Ticino MAGIC module (**)

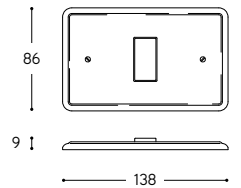

ARTICOLO ITEM	PESO GR. WEIGHT GR.	VOL. IN M ³ VOL. IN M ³	PEZZI IMBALLO OUTER BOX	FASCIA PREZZO PRICE RANGE
1PM1.00 Bianco / White				
1PM1. ... Filo colorato / Coloured line (*)	200	0,002	1	B10
1PM1.C Cotto / Cotto				

Design Studio Leonardo Emiliozzi



Placca 2 posti
per moduli B. Ticino MAGIC (**)
Two - opening plate
for B. Ticino MAGIC modules (**)

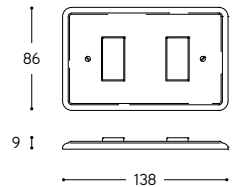

ARTICOLO ITEM	PESO GR. WEIGHT GR.	VOL. IN M ³ VOL. IN M ³	PEZZI IMBALLO OUTER BOX	FASCIA PREZZO PRICE RANGE
1PM2.00 Bianco / White				
1PM2. ... Filo colorato / Coloured line (*)	195	0,002	1	B10
1PM2.C Cotto / Cotto				

Design Studio Leonardo Emiliozzi



Placca 3 posti
per moduli B. Ticino MAGIC (**)
Three - opening plate
for B. Ticino MAGIC modules (**)

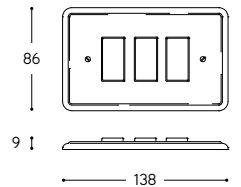

ARTICOLO ITEM	PESO GR. WEIGHT GR.	VOL. IN M ³ VOL. IN M ³	PEZZI IMBALLO OUTER BOX	FASCIA PREZZO PRICE RANGE
1PM3.00 Bianco / White				
1PM3. ... Filo colorato / Coloured line (*)	190	0,002	1	B10
1PM3.C Cotto / Cotto				

Design Studio Leonardo Emiliozzi



Placca 4 posti
per moduli B. Ticino MAGIC (**)
Four - opening plate
for B. Ticino MAGIC modules (**)

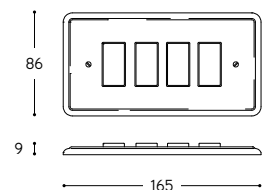

ARTICOLO ITEM	PESO GR. WEIGHT GR.	VOL. IN M ³ VOL. IN M ³	PEZZI IMBALLO OUTER BOX	FASCIA PREZZO PRICE RANGE
1PM4.00 Bianco / White				
1PM4. ... Filo colorato / Coloured line (*)	220	0,002	1	B13
1PM4.C Cotto / Cotto				



Placca 5 posti
per moduli B. Ticino MAGIC (**)
Five - opening plate
for B. Ticino MAGIC modules (**)

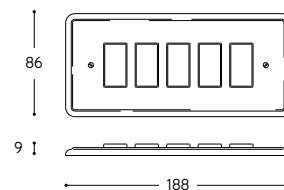

ARTICOLO ITEM	PESO GR. WEIGHT GR.	VOL. IN M ³ VOL. IN M ³	PEZZI IMBALLO OUTER BOX	FASCIA PREZZO PRICE RANGE
1PM5.00 Bianco / White				
1PM5. ... Filo colorato / Coloured line (*)	250	0,004	1	B13
1PM5.C Cotto / Cotto				

(*) ... **FR** = Filo rosso / Red line
 ... **FM** = Filo marrone / Brown line
 ... **FA** = Filo ramina / Green line
 ... **FB** = Filo blu / Blue line
 ... **FO** = Filo arancio / Orange line

(**) **I moduli B. Ticino MAGIC non sono compresi nell'articolo**
B. Ticino MAGIC modules are not provided with the article

I Fili colorati sono illustrati a pag. 184
 See Coloured lines on page 184

Design Studio Leonardo Emiliozzi



Placca 1 posto
per modulo B. Ticino MAGIC (**)
One - opening plate
for B. Ticino MAGIC module (**)

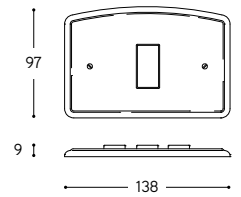

ARTICOLO ITEM	PESO GR. WEIGHT GR.	VOL. IN M ³ VOL. IN M ³	PEZZI IMBALLO OUTER BOX	FASCIA PREZZO PRICE RANGE
2PM1.00 Bianco / White				
2PM1. ... Filo colorato / Coloured line (*)	215	0,002	1	B10
2PM1.C Cotto / Cotto				

Design Studio Leonardo Emiliozzi



Placca 2 posti
per moduli B. Ticino MAGIC (**)
Two - opening plate
for B. Ticino MAGIC modules (**)

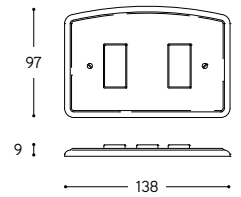

ARTICOLO ITEM	PESO GR. WEIGHT GR.	VOL. IN M ³ VOL. IN M ³	PEZZI IMBALLO OUTER BOX	FASCIA PREZZO PRICE RANGE
2PM2.00 Bianco / White				
2PM2. ... Filo colorato / Coloured line (*)	220	0,002	1	B10
2PM2.C Cotto / Cotto				

Design Studio Leonardo Emiliozzi



Placca 3 posti
per moduli B. Ticino MAGIC (**)
Three - opening plate
for B. Ticino MAGIC modules (**)

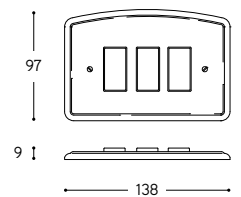

ARTICOLO ITEM	PESO GR. WEIGHT GR.	VOL. IN M ³ VOL. IN M ³	PEZZI IMBALLO OUTER BOX	FASCIA PREZZO PRICE RANGE
2PM3.00 Bianco / White				
2PM3. ... Filo colorato / Coloured line (*)	205	0,002	1	B10
2PM3.C Cotto / Cotto				

(*) ... **FR** = Filo rosso / Red line
 ... **FM** = Filo marrone / Brown line
 ... **FA** = Filo ramina / Green line
 ... **FB** = Filo blu / Blue line
 ... **FO** = Filo arancio / Orange line

(**) **I moduli B. Ticino MAGIC non sono compresi nell'articolo**
B. Ticino MAGIC modules are not provided with the article

I Fili colorati sono illustrati a pag. 184
 See Coloured lines on page 184

Design Studio Leonardo Emiliozzi



Placca 1 posto
per modulo B. Ticino MAGIC (**)
One - opening plate
for B. Ticino MAGIC module (**)

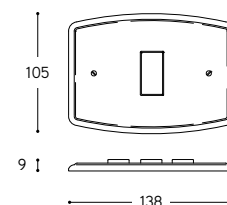

ARTICOLO ITEM	PESO GR. WEIGHT GR.	VOL. IN M ³ VOL. IN M ³	PEZZI IMBALLO OUTER BOX	FASCIA PREZZO PRICE RANGE
3PM1.00 Bianco / White				
3PM1. ... Filo colorato / Coloured line (*)	235	0,002	1	B10
3PM1.C Cotto / Cotto				

Design Studio Leonardo Emiliozzi



Placca 2 posti
per moduli B. Ticino MAGIC (**)
Two - opening plate
for B. Ticino MAGIC modules (**)

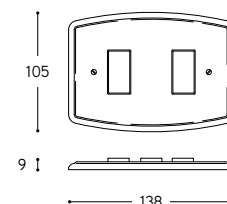

ARTICOLO ITEM	PESO GR. WEIGHT GR.	VOL. IN M ³ VOL. IN M ³	PEZZI IMBALLO OUTER BOX	FASCIA PREZZO PRICE RANGE
3PM2.00 Bianco / White				
3PM2. ... Filo colorato / Coloured line (*)	225	0,002	1	B10
3PM2.C Cotto / Cotto				

Design Studio Leonardo Emiliozzi



Placca 3 posti
per moduli B. Ticino MAGIC (**)
Three - opening plate
for B. Ticino MAGIC modules (**)

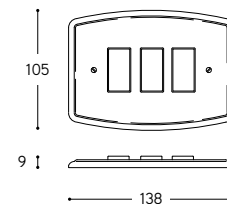

ARTICOLO ITEM	PESO GR. WEIGHT GR.	VOL. IN M ³ VOL. IN M ³	PEZZI IMBALLO OUTER BOX	FASCIA PREZZO PRICE RANGE
3PM3.00 Bianco / White				
3PM3. ... Filo colorato / Coloured line (*)	220	0,002	1	B10
3PM3.C Cotto / Cotto				

(*) ... **FR** = Filo rosso / Red line
 ... **FM** = Filo marrone / Brown line
 ... **FA** = Filo ramina / Green line
 ... **FB** = Filo blu / Blue line
 ... **FO** = Filo arancio / Orange line

(**) **I moduli B. Ticino MAGIC non sono compresi nell'articolo**
B. Ticino MAGIC modules are not provided with the article

I Fili colorati sono illustrati a pag. 184
 See Coloured lines on page 184

Per un corretto montaggio For correct assembling

- 1 Consigliamo di mettere gli isolatori ad una distanza di 30/35 cm l'uno dall'altro segnando sul muro il loro corretto posizionamento
- 1 It is advisable to place the isolators at a distance of 30/35 cm from each other, marking their correct position on the wall.

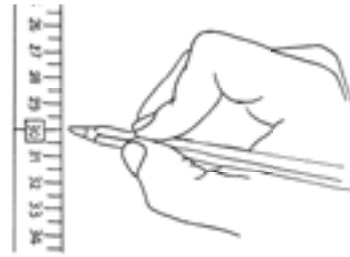

- 2 Assicurarsi che a 3 cm dall'entrata della treccia sugli accessori da installare, ci sia lo spazio per mettere un isolatore fig. A e fig. B
- 2 Ensure that there is space to fit the isolator at 3 cm from the entrance of the braid on the accessories being installed, fig. A and fig. B

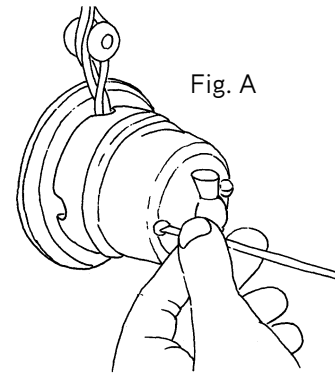

Fig. A

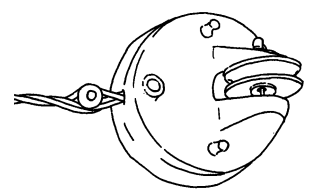
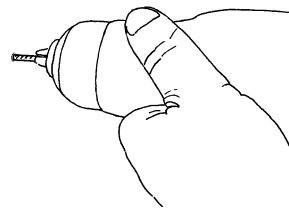
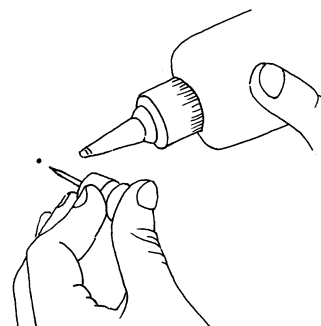

Fig. B

- 3 Forare la parete con una punta da trapano di mm 2.
- 3 Drill the wall with a 2 mm drill bit.



- 4 Interporre una goccia di colla vinilica o attack sulla punta del chiodo in dotazione, precedentemente già inserito nell'isolatore.
- 4 Place a drop of vinyl glue or super glue on the tip of the supplied nail after passing it through the insulator.



- 5 Fissare l'isolatore sulla parete; prestare attenzione a non danneggiare la ceramica con il martello.
- 5 Fix the isolator to the wall taking care not to damage the ceramic part with the hammer.

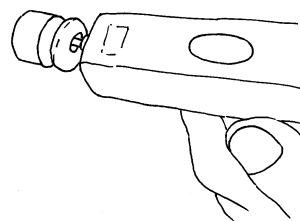

- 6 Procedere ora al posizionamento della treccia.
Per una buona tensione: inserire la treccia nel primo isolatore, avvolgerla su se stessa in senso orario, posizionarla sul secondo isolatore e procedere così di seguito fino a quando si arriva sull'accessorio da collegare.

- 6 The braid can now be positioned.
To get the correct tension: pass the braid through the first isolator, winding it around itself in a clockwise direction, pass it through the second isolator and so on until it reaches the accessory that is being connected.

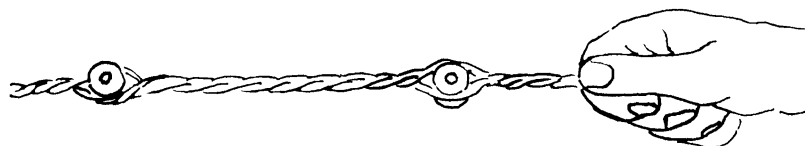

- 7 Per deviazioni o curve possono essere utilizzati gli accessori di nostra produzione (passabili ad angolo retto o curvo). fig. F in alternativa collocare due isolatori ad angolo retto, ad una distanza di 5/7 cm l'uno dall'altro come da fig. G

- 7 If there are any branches or curves, our original accessories should be used (for right-angled or curved corners), fig. F alternatively, place two isolators at right angles at a distance of 5/7 cm from each other, as shown in fig. G

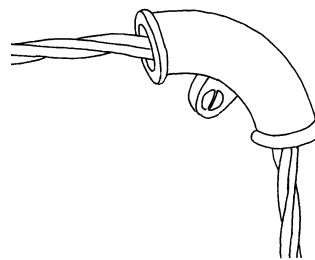

Fig. F

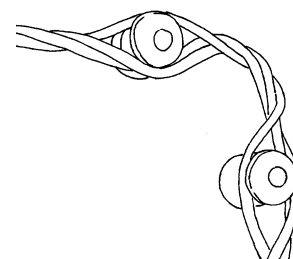
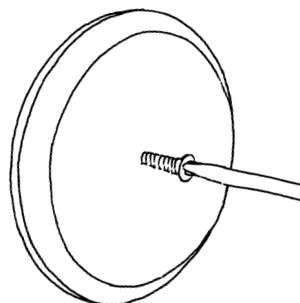

Fig. G

- 8 Per l'installazione di prese, interruttori, scatole di derivazione, spot, basi per applique a 45°, plafoniere e rosoni per decentramento consigliamo di interporre tra la parete e l'accessorio la rosetta in legno di nostra produzione fig. H

- 8 Place our original wood washers between the wall and the accessory to install any sockets, switches, connector boxes, spotlights, bases for wall lights at 45°, ceiling lights and ceiling roses, fig. H



- 9 Procedere ora al collegamento elettrico come da istruzioni di montaggio.
- 9 The electric wiring can now be completed as explained in the assembly instructions.

FILI COLORATI COLOURED LINES

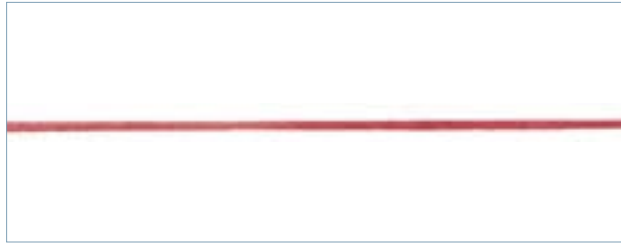
**FR**

Filo rosso
Red line

**FM**

Filo marrone
Brown line

**FA**

Filo ramina
Green line

**FB**

Filo blu
Blue line

**FO**

Filo arancio
Orange line

DECORI DECORATIONS

**01**

Delft blu
Delft

**05**

Vite
Grapevine

**06**

Anemone
Anemone

**07/V**

Greca in verde
Green greek fret

**08/B**

Greca in blu
Blue greek fret



35
Primavera blu
Blue spring



38
Bordo verde
Green border



116
Edera blu
Blue ivy



117
Edera rossa
Red ivy



118
Edera verde
Green ivy



313
Foglie
Leaf



412
Tulipani
Tulip



IB
Intreccio blu
Blue intertwine

RIFLETTORI RAME

COPPER SHADES

**01**Conico
Conic**03**Tondo piccolo
Small round**04**Tondo grande
Big round

FINITURE LED

LED FINISHES



BL
Bianco lucido
Glossy white

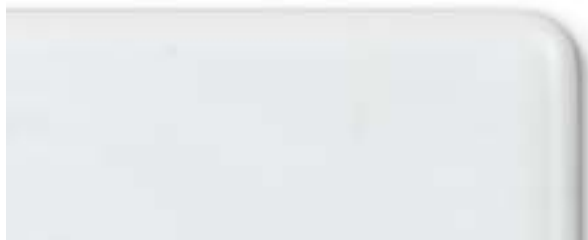

BO
Bianco opaco
Matte white



NL
Nero lucido
Glossy black



NO
Nero opaco
Matte black



MR
Metal rame
Copper metal



R
Rosso opaco
Matte red













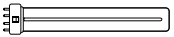
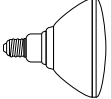

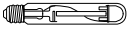

VL
Verde lucido
Glossy green



CT
Craquellé
Turquoise
Turquoise
Craquele

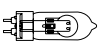



LAMPADINE BULBS

ARTICOLO ITEM	LAMPADA BULB	TIPO TYPE	ATTACCO SOCKET	POTENZA POWER
	Alogena / Halogen	Bulbo standard / Standard bulb	E14	28/42W
	Alogena / Halogen	Bulbo standard / Standard bulb	E27	42/70W
	Fluorescente / Fluorescent	Compatta / Compact	G24d-1	13W
			G24d-2	18W
			G24d-3	26W
	Fluorescente / Fluorescent	Compatta / Compact	2G11 TCL	24/36W
	Fluorescente / Fluorescent	PAR38	E27	23W
	Sodio alta pressione / High pressure sodium	Ellissoidale / Ellipsoidal	E27	70W
	Sodio alta pressione / High pressure sodium	Tubolare / Tubular	E27	70W
	Alogena / Halogen	Tubolare / Tubular	E27	200W
	Alogena PAR20 / Halogen PAR20	Con riflettore / With reflector	E27	50W
	Alogena lineare 117 mm / Halogen linear 117 mm	Tubolare / Tubular	R7S	120W
	Alogena lineare 78 mm / Halogen linear 78 mm	Tubolare / Tubular	R7S	42/80W
	Dicroica / Dichroic	Con riflettore / With reflector	Gx5,3	35W
	Dicroica / Dichroic	Con riflettore / With reflector	GU 10SP	50W
	Halopin / Halopin	Tubolare / Tubular	G9	25/75W
	Alogenuri metallici / Metal halide	Tubolare / Tubular	G12	70/150W
	Fluorescente / Fluorescent	Compatta / Compact	GX53	9W

LEGENDA LEGEND

Tutti gli apparecchi di illuminazione vengono forniti senza lampade. Il “peso in gr.” degli articoli si intende “lordo”.
Le dimensioni sono espresse in mm.

All lamps are supplied without bulbs. The weight means “gross weight”. Dimensions are in millimeters.

IP	Grado di protezione contro la penetrazione di corpi solidi e acqua. Degree of protection against penetration of solid bodies and water.
IP20	Protezione contro l'ingresso di corpi solidi di \varnothing 12 mm. Nessuna protezione contro la pioggia. Protection against entry of solid bodies of \varnothing 12 mm. No protection against rain.
IP40	Protezione contro l'ingresso di corpi solidi di \varnothing 1 mm. Nessuna protezione contro la pioggia. Protection against entry of solid bodies of \varnothing 1 mm. No protection against rain.
IP43	Protezione contro l'ingresso di corpi solidi di \varnothing 1 mm. e contro la pioggia. Protection against entry of solid bodies of \varnothing 1 mm. and against rain.
IP44	Protezione contro l'ingresso di corpi solidi di \varnothing 1 mm e contro gli spruzzi d'acqua provenienti da tutte le direzioni. Protection against entry of solid bodies of \varnothing 1 mm. and against water sprays coming from all directions.
CE	Marcatura richiesta dalle direttive europee 93/68 e 89/336. Marking required by european directives 93/68 and 89/336.
	Apparecchio in classe I di isolamento. Appliance class I insulation.
	Apparecchio in classe II di isolamento. Appliance class II insulation.
	Apparecchio in classe III di isolamento. Appliance class III insulation.
	Apparecchio e lampada che non richiede schermo di protezione. Appliance and lamp not requiring protection screen.
	<p>Informazioni all'utilizzatore ai sensi dell'Art 13 del Dlgs 151/05 - Attuazione delle Direttive Europee 2002/95/CE, 2002/96/CE e 2003/108/CE - (Rifiuti di apparecchiature elettriche ed elettroniche - RAEE). Il simbolo del cassonetto barrato a fianco riportato indica che questa apparecchiatura deve essere oggetto di raccolta separata. È fatto quindi obbligo di non smaltire questo prodotto giunto a fine vita come rifiuto urbano.</p> <p>Lo smaltimento deve essere effettuato presso gli appositi sistemi di raccolta dei rifiuti di questo tipo, oppure mediante riconsegna al distributore all'atto di acquisto di un analogo prodotto nuovo.</p> <p>Assicurandosi che questo prodotto sia smaltito correttamente, ed evitandone usi impropri, si contribuisce ad impedire possibili conseguenze negative all'ambiente e alla salute delle persone, data la presenza al loro interno di sostanze potenzialmente pericolose.</p> <p>Lo smaltimento deve avvenire in accordo con la normativa vigente per lo smaltimento dei rifiuti, pena le sanzioni previste in caso di smaltimento abusivo di detti rifiuti (RAEE).</p> <p>Lo smaltimento abusivo del prodotto da parte dell'utente comporta l'applicazione delle sanzioni amministrative di cui all'articolo 50 e seguenti del D.Lgs. N. 22/1997 Come modificato dal D.Lgs. 3-4-2006 N. 152 successive modifiche e integrazioni.</p> <p>Information for users in accordance with European Directives 2002/95/CE and 2003/108/CE on the restriction of the use of dangerous substances in electric and electronic equipment as well as their waste disposal. The burred symbol of the rubbish bin shown on the equipment indicates that, at the end of its useful life, the product must be collected separately from the other waste.</p> <p>Therefore, any products that have reached the end of their useful life must be given to waste disposal centres specialising in separate collection of waste electrical and electronic equipment, or given back to the retailer at the time of purchasing new similar equipment, one a one for one basis.</p> <p>The adequate separate collection for the subsequent start-up of the equipment sent to be recycled, treated and disposal of in an environmentally, compatible way contributes to preventing possible negative effects on the environment and health and optimises the recycling and reuse of components making up the apparatus.</p> <p>Abusive disposal of the product by the user involves application of the administrative sanctions according to the laws in force.</p>

INDICE INDEX

ARTICOLO ITEM	PAGINA PAGE	ARTICOLO ITEM	PAGINA PAGE	ARTICOLO ITEM	PAGINA PAGE	ARTICOLO ITEM	PAGINA PAGE
1PM.S	177	120	17	4600.1	65	GLA.1	105
1PM1	178	200	21	4600.2	65	GLA.2	105
1PM2	178	205	21	4600.3	65	GLA.3	105
1PM3	178	210	21	9120	49	LAR.02	176
1PM4	178	215	21	9122	49	LAR.05	176
1PM5	179	220	21	9132	49	LAR.10	150
1PMIDEA	177	310	22	9133	49	LAR.12	151
1PMPLANA	177	315	22	9351	53	LAR.13	151
1PMTT	177	320	22	9421	51	LAR.15	151
2PM1	180	800	27	9422	51	LAR.15/TEL	151
2PM2	180	805	27	9521	55	LAR.15/TV/SAT	151
2PM3	180	808	27	9522	55	LAR.20	152
3PM1	181	810	27	9611	56	LAR.22	153
3PM2	181	813	27	9910	45	LAR.23	153
3PM3	181	815	27	9915	45	LAR.25	153
10.120	94	820	31	9920	45	LAR.25/TEL	153
10.320	90	823	31	B1	122	LAR.25/TV/SAT	153
10.521	92	2010	35	B2	124	LAR.30	154
10.720	91	2015	35	B3	126	LAR.32	155
11.620	95	2020	35	DO.A1	111	LAR.33	155
40/B	118	2022	35	DO.A2	111	LAR.35	155
40/D	118	2100	39	E30	108	LAR.35/TEL	155
41.820	31	2105	39	E45	108	LAR.35/TV/SAT	155
41.823	31	2110	39	FUNNEL	61	LAR.55/FRANCIA	161
41.9331	53	2115	39	G05	106	LAR.55/SCHUKO	161
41.9820	57	2120	39	G10	81	LAR.70	71
41.21000	98	3610	40	G11	81	LAR.71	77
41.22000	96	3615	40	G130	83	LAR.74	73
100	17	3620	40	G132	83	LAR.80	116
105	17	3910	42	G311	86	LAR.85	117
110	17	3915	42	G330	85	LAR.91	77
115	17	3920	42	G331	85	LAR.93	115

ARTICOLO ITEM	PAGINA PAGE	ARTICOLO ITEM	PAGINA PAGE	ARTICOLO ITEM	PAGINA PAGE	ARTICOLO ITEM	PAGINA PAGE
LAR.94	73	LAR.138.10/MT.	173	LAR.INT.03	171	RO1	168
LAR.95	77	LAR.138.11/CONF.	173	LAR.P1	164	RO2	168
LAR.97	115	LAR.138.11/MT.	173	LAR.P1/FRANCIA	165	RO3	168
LAR.98	73	LAR.138.12/CONF.	173	LAR.P1/INTE	165	RO7	168
LAR.116	175	LAR.138.12/MT.	173	LAR.P1/SCHUKO	165	RO8	168
LAR.120	175	LAR.140	156	LAR.P1/TEL	165	RO9	168
LAR.126	175	LAR.141	157	LAR.P1/TV/SAT	165	RO10	168
LAR.130	174	LAR.141/TEL	157	LAR.P13	160	RO11	168
LAR.131/CONF.	174	LAR.141/TV/SAT	157	LAR.P13/FRANCIA	160	RO12	168
LAR.131/ISO	174	LAR.142	157	LAR.P13/SCHUKO	160	RO13	169
LAR.132	174	LAR.158	69	LAR.P13/TEL	160	RO14	169
LAR.133	173	LAR.159	69	LAR.P13/TV/SAT	160	RO15	169
LAR.134	176	LAR.160	69	LAR.PRE.01	171	S1	128
LAR.138.01/CONF.	173	LAR.187	145	LAR.PRE.03	171	S2	128
LAR.138.01/MT.	173	LAR.187/DIMMER	145	M1	132	S3	130
LAR.138.02/CONF.	173	LAR.188	145	M2	132	S4	130
LAR.138.02/MT.	173	LAR.188/INTE	145	OND1	166	SI.A6	100
LAR.138.03/CONF.	173	LAR.188/TEL	146	OND2	166	T1	137
LAR.138.03/MT.	173	LAR.188/TV/SAT	146	OND3	166	T2	137
LAR.138.04/CONF.	173	LAR.189	146	OND7	166	TEM	120
LAR.138.04/MT.	173	LAR.190	148	OND8	166		
LAR.138.05/CONF.	173	LAR.191	149	OND9	166		
LAR.138.05/MT.	173	LAR.191/TEL	149	OND10	166		
LAR.138.06/CONF.	173	LAR.191/TV/SAT	149	OND11	166		
LAR.138.06/MT.	173	LAR.192	149	OND12	166		
LAR.138.07/CONF.	173	LAR.DER	171	OND13	167		
LAR.138.07/MT.	173	LAR.ID1	164	OND14	167		
LAR.138.08/CONF.	173	LAR.ID1/DIMMER	164	OND15	167		
LAR.138.08/MT.	173	LAR.ID2	164	R1	137		
LAR.138.09/CONF.	173	LAR.ID9	158	R2	137		
LAR.138.09/MT.	173	LAR.ID9/DIMMER	159	R3	137		
LAR.138.10/CONF.	173	LAR.INT.01	170	RAGGIO BIANCO	102		

Aldo Bernardi S.r.l.
Via Vittorio Veneto 2/A
31017 Paderno del Grappa
Treviso, Italia

T +39 0423.538783
F +39 0423.539082

info@aldobernardi.it
www.aldobernardi.it



Copyright © 2012 Aldo Bernardi S.r.l.

Aldo Bernardi S.r.l. si riserva il diritto di effettuare modifiche ai prodotti senza l'obbligo di preavviso. Tutti i diritti sono riservati. I decori e tutti gli oggetti rappresentati nel catalogo possono produrre colori e tonalità non perfettamente fedeli agli originali. Il rame e l'ottone possono avere tonalità diverse da quelle raffigurate nelle foto del catalogo. Il rame e l'ottone non sono verniciati ma sottoposti ad un processo di anticatura. Ciò è dovuto alla lavorazione manuale del procedimento di anticatura. L'anticatura del rame e dell'ottone, effettuata artigianalmente, accelera ma non sostituisce l'ossidazione naturale di questi materiali che, esposti all'esterno, subiranno l'azione degli agenti specifici presenti nell'aria, diversi da zona a zona.

Aldo Bernardi S.r.l. reserves the right to modify products, without notice, anytime. All rights reserved. Decorations and all the objects represented in the catalogue can reproduce colours and shades not perfectly true to the original. Copper, brass and casting can take on different shades to those given in the catalogue. Copper and brass are not painted they are submitted to an aging process. The aging, manufacturing process, speeds up, but does not replace the natural oxidation of these materials. Copper and brass natural aging process, positioned in different environment, will be subjected to the influence of different atmospheric agents, depending from the environment.

Photo
Quasar
M. Gaddo
Mario Reggiani

Print
IMOCO

Si ringrazia per la collaborazione / Thanks for collaboration
Studio progettazione interno

IMOCO.LC
REV. 00/18

